

| INSTALLATION & OPERATION MANUAL

MEF 2100 C

Inline Electromagnetic Flow Meter



MIAL[®]
INSTRUMENTS PVT.LTD.
Measuring & Beyond

www.mialinstruments.com

MEF 2100 C

Inline Electromagnetic Flow Meter

Preface

- Thank you for purchasing our product.
- This manual is about the various functions of the product, wiring methods, setting methods, operating methods, troubleshooting methods, etc.
- Please read this manual carefully before operation, use this product correctly to avoid unnecessary losses due to incorrect operation.
- After you finish reading, please keep it in a place where it can be easily accessed at any time for reference during operation.



NOTE!

Modification of this manual's contents will not be notified as a result of some factors, such as function upgrading. We try our best to guarantee that the manual content is accurate, if you find something wrong or incorrect, please contact us. The content of this manual is strictly prohibited from reprinting or copying.

About this manual

- Please submit this manual to the operator for reading.
- Please read the operation manual carefully before installing the instrument. On the precondition of full understanding.
- This manual only describes the functions of the product. The MIAL Instruments pvt.ltd. does not guarantee that the product will be suitable for a particular application.

Warnings and symbols used



HAZARD!

If not taken with appropriate precautions, will result in serious personal injury, product damage or major property damage.



WARNING!

Pay special attention to the important information linked to product or particular part in the operation Manual



CAUTION!

Disregarding these instructions can result in damage to the device or to parts of the operator's plant.



INFORMATION!

These instructions contain important information for the handling of the device.



Table of Contents

PREFACE	2
ABOUT THIS MANUAL	2
1. INTRODUCTION	5
1.1 PURPOSE OF THE MANUAL.....	5
1.2 OPERATING PRINCIPLE.....	6
1.3 TECHNICAL SPECIFICATIONS.....	7
1.4 SUPPLEMENTARY ACCESSORIES THAT COULD BE NEEDED.....	9
1.4.1 GROUNDING RINGS.....	9
2. DEVICE DESCRIPTION	11
2.1 SCOPE OF DELIVERY.....	11
2.2 NAMEPLATES.....	12
3. INSTALLATION	13
3.1 INSTALLATION OF FLOW METER.....	13
3.2 REQUIREMENTS FOR STRAIGHT PIPE SECTION.....	13
3.3 INSTALLATION DRAWING FOR NON- CONDUCTIVE PIPE.....	15
3.4 FLOW SENSOR DIMENSION.....	16
3.5 PREPARATION BEFORE OPERATION.....	17
4. ELECTRICAL CONNECTIONS	18
4.1 SAFETY INSTRUCTION.....	18
4.2 CONNECT SIGNAL & MAGNETIC FIELD CURRENT CABLE.....	18
4.3 INSTRUMENT PARAMETER SETTING & DESCRIPTION.....	19
4.4 INSTRUMENT MENU.....	21
4.5 WIRING DIAGRAM.....	21
4.6 MEF 2100 C MODBUS CONFIGURATION.....	22
4.7 CONNECTED POWER.....	22
4.8 EARTH CONNECTIONS.....	23
4.9 FREQUENCY PULSE O/P.....	24
4.10 CURRENT O/P INTERFACE.....	26
4.11 COMMUNICATION PROTOCOL.....	27
APPENDIX I : FLOW RANGE CHART.....	30
APPENDIX II: TROUBLESHOOTING.....	31



1. INTRODUCTION

1.1 PURPOSE OF THE MANUAL

Overview:

Welcome to the user manual for the Mial MEF 2100 C - Electromagnetic Flowmeter. This comprehensive guide is designed to assist operators, maintenance personnel, and system integrators in understanding, installing, operating, and maintaining the Mial MEF 2100 C - Electromagnetic flow meter effectively.

Objectives:

Clarification of Functionality: This manual aims to provide a clear understanding of the principles and functionality of the Mial MEF 2100 C - Electromagnetic Flowmeter. Users will gain insights into its design, components, and how it precisely measures fluid flow.

Guidance for Installation:

Step-by-step instructions and considerations for proper installation are provided to ensure optimal performance. Safety precautions are emphasized to create a secure working environment.

Training and Familiarization:

Users will be guided through the features, controls, and indicators of the flow meter, facilitating efficient operation. This section aims to serve as a valuable training resource for users at various experience levels.

Maintenance and Troubleshooting Assistance:

Learn about routine maintenance procedures and effective troubleshooting techniques. This manual empowers users to address common issues and perform regular maintenance to enhance the longevity of the Mial MEF 2100 C - Electromagnetic Flowmeter.

Intended Audience:

This manual is intended for operators, maintenance personnel, and system integrators involved in the installation, operation, and maintenance of the Mial MEF 2100 C - Electromagnetic Flowmeter. It is suitable for both novice users seeking basic guidance and experienced professionals looking for specific details.

Important Notes:

Please read through the manual carefully, adhering to safety guidelines and following instructions precisely. If any uncertainties arise during the installation, operation, or maintenance processes, seek assistance from qualified personnel or our customer service / support team.

Reference to Other Documentation:

Refer to the accompanying technical specifications document for in-depth details about the Mial MEF 2100 C - Electromagnetic Flowmeter. Additional resources can be found on our website.

Intended use



CAUTION!

Responsibility for the use of the measuring devices with regard to suitability, intended use and corrosion resistance of the used materials against the measured fluid lies solely with the operator.



INFORMATION!

The manufacturer is not liable for any damage resulting from improper use or use for other than the intended purpose

Certification



The manufacturer certifies successful testing of the product by applying the CE marking



The manufacturer certifies successful testing of the product by applying the ISO marking

1.2 OPERATING PRINCIPLE

The Electromagnetic flow meter operates by inducing a magnetic field across a pipe through which a conductive fluid flows. Coils or electrodes generate the magnetic field, and as the fluid moves through, it cuts across the field, adhering to Faraday's Law of Electromagnetic induction. This results in the generation of an induced voltage in the fluid, which is picked up by electrodes on the opposite sides of Flow tube. The magnitude of this voltage is directly proportional to the flow rate of the fluid. The meter's electronics process these voltage signals to calculate and display the flow rate. Notably effective for measuring conductive fluids like water, Electromagnetic flow meters are particularly valuable for applications involving abrasive or corrosive substances. The accuracy of the measurements is contingent on factors such as the uniformity of the magnetic field and the conductivity of the fluid being measured. Users should refer to the manufacturer's manual for precise instructions on installation and calibration.

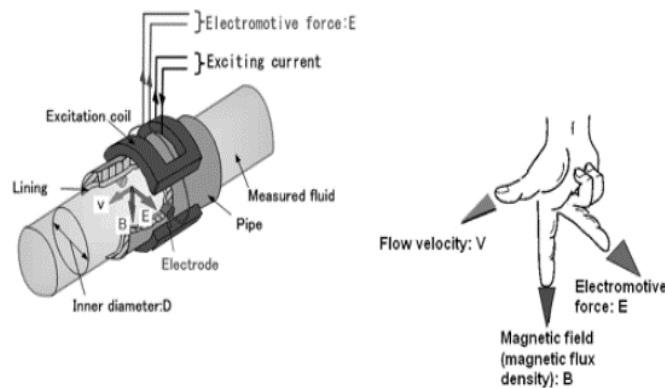

1.3 TECHNICAL SPECIFICATIONS*

Operation and performance

Flow measurement Technology

The flow measurement technology of electromagnetic flow meters is based on Faraday's law of electromagnetic induction, where the induced voltage across electrodes is proportional to the fluid velocity, allowing for accurate flow measurement.

Fluid types

Electrically conductive fluids such as water (Hot Water, Chilled Water, Condensate Water, Domestic Water, Waste Water etc.)

Conductivity

≥ 20 μS/cm

Pipe sizes

15 MM – 300 MM

Pipe materials

Metallic and Non Metallic pipes.

Flow accuracy

Standard : ±0.5%

Achievable with process calibration

Repeatability

Flow: ±0.15%

Linearity Standard: ±0.5%

Measuring range

0.09ft/s – 40 ft/s

Measurement parameters

Flow Meter– Instantaneous flow rate, totalized flow

Certification

Factory calibration certification, CE, ISO

Electronics

Enclosures

Aluminum (Integral)

Use weather proof enclosure while installing the transmitter outside

Enclosure IP rating

IP 65

Memory

EEPROM

Power supply

24 VDC/2A

Use 2-amp SMPS when employing AC power

Ambient temperature

32°F to 140°F (0°C to 60°C)

Relative Humidity

5– 95% RH

Standard Analog outputs

Flow meter– 4–20 mA

Output programmed for current flow rate. 750 Ω maximum load

Pulse Outputs

Flow Meter– Pulse

Programmed for Flow Consumption , Contact pulse Duration – 0.1~300 ms

Network Connection

Modbus RTU RS485

Flow tube specification

Coil material

Pure Copper

99% copper (Cu) content, excellent electrical conductivity, corrosion resistance

Process connections

Standard: ANSI 150 flanges Optional: ANSI 300 flanges

Operating temperature

14°F to 248°F (–10°C to 120°C)

Nominal Pressure

Standard: 1.6 Mpa

Optional: 2.5 Mpa,

Flow Tube

Standard :SS 304 Optional : SS 316

Electrode Material

Standard: SS 316L

Optional: Hastelloy, Titanium, Tantalum,

Liner

Standard: PTFE

Optional: Ebonite, Polyebonite, Polyurethane, PFA

Flange

Standard: Carbon Steel Optional: Stainles steel

Mountings

Flanged flow tube

IP rating

Flow tube : IP68

*Specifications are subject to change without prior notice



1.4 SUPPLEMENTARY ACCESSORIES THAT COULD BE NEEDED

1.4.1 GROUNDING RINGS

Grounding rings may be needed when meters are installed in non-metallic pipes or lined pipes. Placing these rings before and after the meter helps to reduce electrical interference, allowing the meter to function accurately. Mial Instruments provides these grounding rings as an optional accessories.

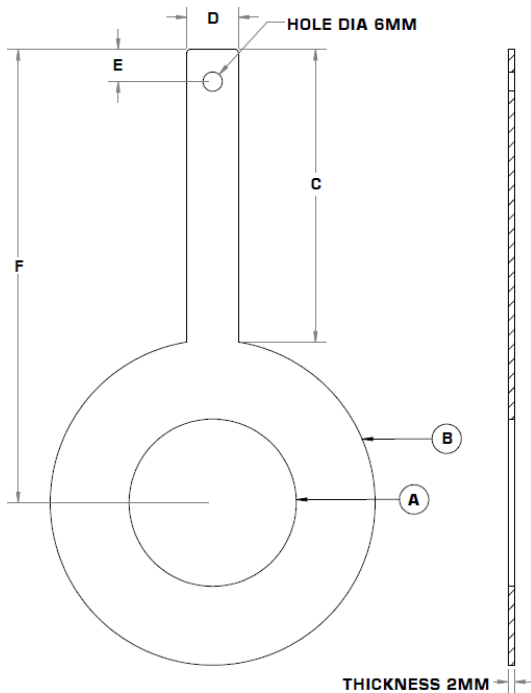







GROUNDING RING SIZES						
ALL DIAMENSIONS ARE FOR FLANGE 150#						
SIZE (MM)	A (ID)	B (OD)	C	D	E	F
15	18	40	50	16	10	70
20	23	42	60	16	10	81
25	26	62	60	16	10	91
32	32	63	60	16	10	91.5
40	40	80	60	16	10	100
50	52	101	60	16	10	110.5
65	63	104	70	20	10	122
80	80	130	70	20	10	135
100	104	158	75	20	10	154
125	130	187	75	20	10	168.5
150	158	217	75	20	10	183.5
200	206	267	75	20	10	208.5
250	260	328	75	20	10	239
300	310	375	85	20	10	272.5

ALL DIAMENSIONS IN MM



2 DEVICE DESCRIPTION

2.1 SCOPE OF DELIVERY

-  **INFORMATION!**
Do a check of the packing list to make sure that you have all the elements given in the order
-  **INFORMATION!**
Inspect the packaging carefully for damages or signs of rough handling. Report damage to the carrier and to the local office of the manufacturer.
-  **INFORMATION!**
The field device will arrive in one standard cartons. The standard carton contains one small corrugated box containing Transmitter Unit. Also, the standard carton box contains Flow Tube ,Product documentation, Test Certificates, Allen key & bolts sets
-  **INFORMATION**
The MEF 2100 C transmitters and sensor bodies are components of a uniquely calibrated system and must be installed together as per the serial number. Mixing components from other systems will result in significant calibration errors. The transmitter serial number can be found on the sticker on the side of the electronics enclosure, and the sensor serial number is located on the sticker on the sensor body.
-  **INFORMATION!**
Mandatory to loop between the grounding rings by using a proper wire and connect the end of the wire to a ground source in the DDC panel.
-  **INFORMATION!**
Grounding Ring will be provided only if the pipe material is Non-Metallic & will be charged additional

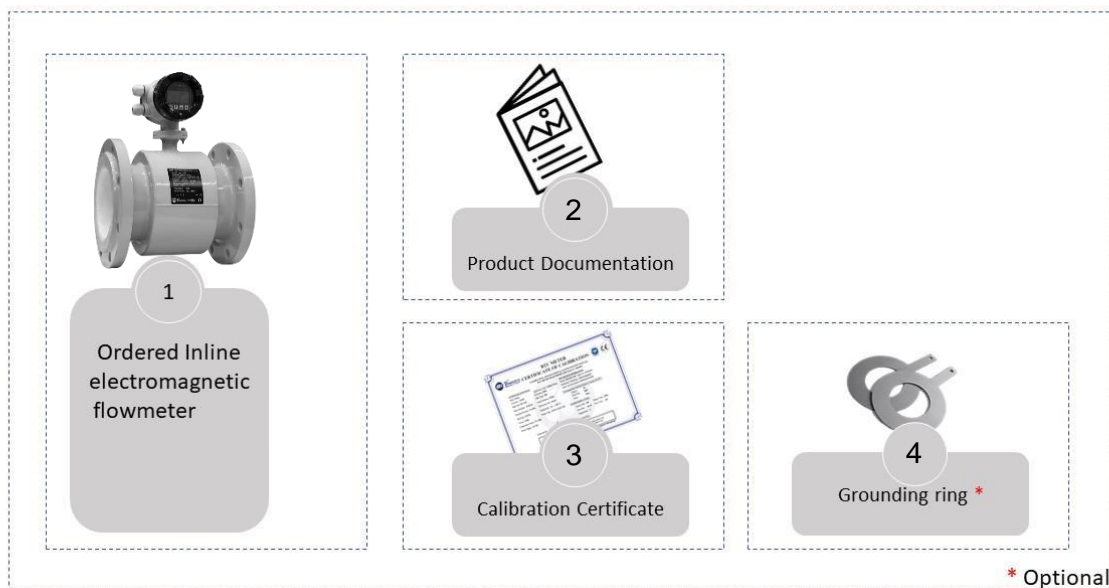

2.2 NAMEPLATES

INFORMATION!

Look at the device nameplate to ensure that the device is delivered according to your order. Check for the correct supply voltage printed on the nameplate

NAMEPLATE FOR THE FLOW TUBE





3 INSTALLATION

3.1 INSTALLATION OF ELECTROMAGNETIC FLOWMETER

- Electromagnetic flowmeters should be avoided to be installed in places with large temperature changes or high temperature radiation of equipment. If installation is necessary, heat insulation and ventilation measures must be taken;
- The electromagnetic flowmeter is best installed indoors. If it must be installed outdoors, it should avoid rainwater, flooding and sun exposure, and must have moisture-proof and sun-proof measures;
- The electromagnetic flowmeter should be avoided to be installed in the environment containing corrosive gas, and ventilation measures must be taken when it must be installed;
- For the convenience of installation, maintenance and maintenance, there should be ample installation space around the flowmeter;
- The electromagnetic flowmeter installation site should avoid magnetic fields and strong vibration sources. There are supports for fixed pipes

INSTALLATION METHOD

- It should be installed at the lower part of the horizontal pipeline and vertically upward, and avoid installing it at the highest point and the vertical downward part of the pipeline;
- It should be installed at the rising place on the pipeline;
- When installed in an open discharge pipeline, it should be installed at the lower part of the pipeline;
- If the pipeline drop exceeds 5m, install an exhaust valve downstream of the sensor;
- The control valve and shut-off valve should be installed downstream of the sensor, but not upstream of the sensor;
- The sensor must not be installed at the inlet and outlet of the pump, but should be installed at the outlet of the pump

3.2 REQUIREMENTS FOR STRAIGHT PIPE SECTIONS

DOCKING SITE REQUIREMENTS

In order to make the instrument work reliably and improve the measurement accuracy, it will not be disturbed by the external parasitic potential / the sensor should be well grounded, and the grounding resistance should be less than 10. (If the metal pipe is well grounded, no special grounding device is required).

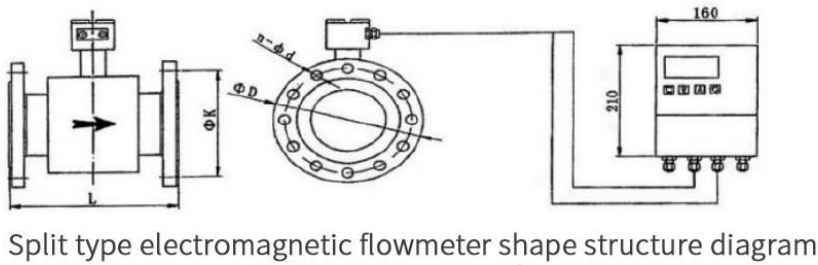
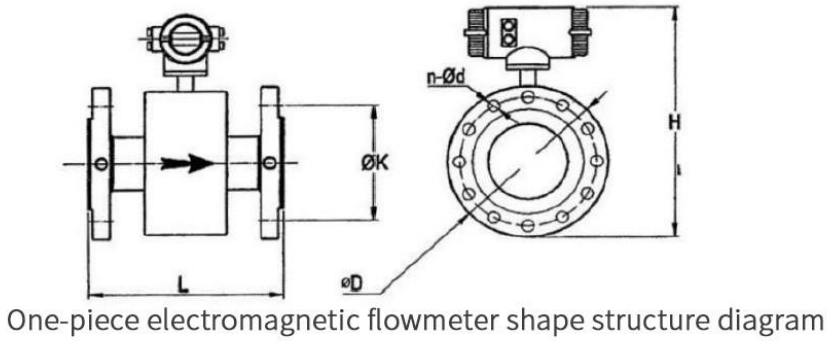
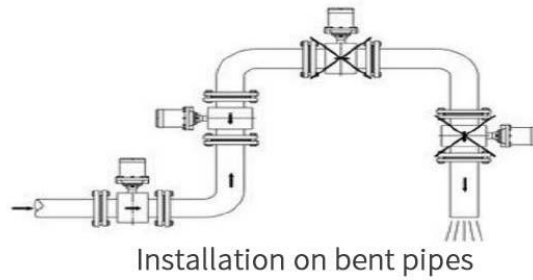
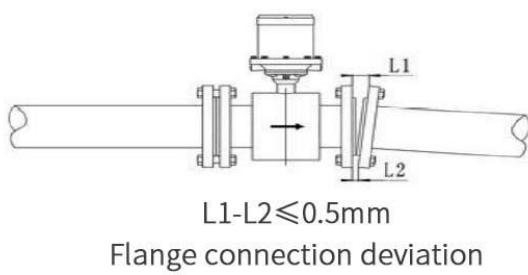
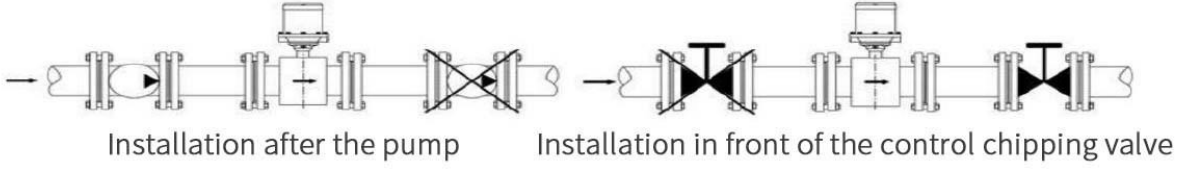



3.3 INSTALLATION DRAWINGS FOR NON-CONDUCTIVE PIPE

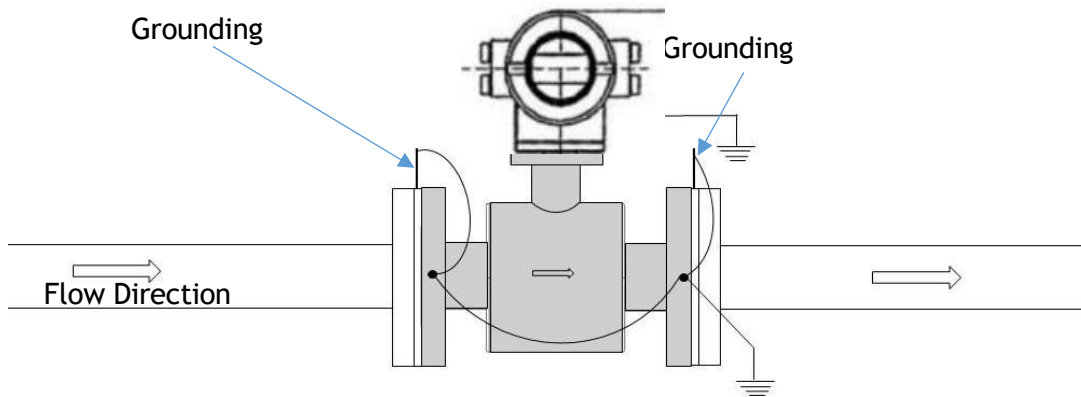

CAUTION

Make sure to connect the earth wires like the picture shows. If you don't, the meter might not work right.

INSTALLATION STEPS



WARNING!

Only trained workers should install this product, and they must follow all the rules for buildings.

1. Clean all flange surfaces well, making sure to remove any old gasket material or adhesive
2. Check all flange surfaces for any bending, dents, or other problems that might stop a good seal.
3. Use new bolts, nuts, and strong washers. Before putting them in, apply lubricant to the bolt threads, nuts, washer sides, and under the bolt head. This helps spread pressure evenly on the seal. Be careful not to get any lubricant on the liner or gasket.
4. Place the new gasket in the middle of the liner surface. Make sure the gasket doesn't stick out into where the liquid flows.
5. Use a torque wrench to tighten the bolts in three stages: first 30%, then 60%, and finally 100%. Tighten them in a repeating pattern.



3.4 FLOW SENSOR DIMENSIONS

ANSI CLASS 150 FLANGED SENSOR OVERALL DIMENSION

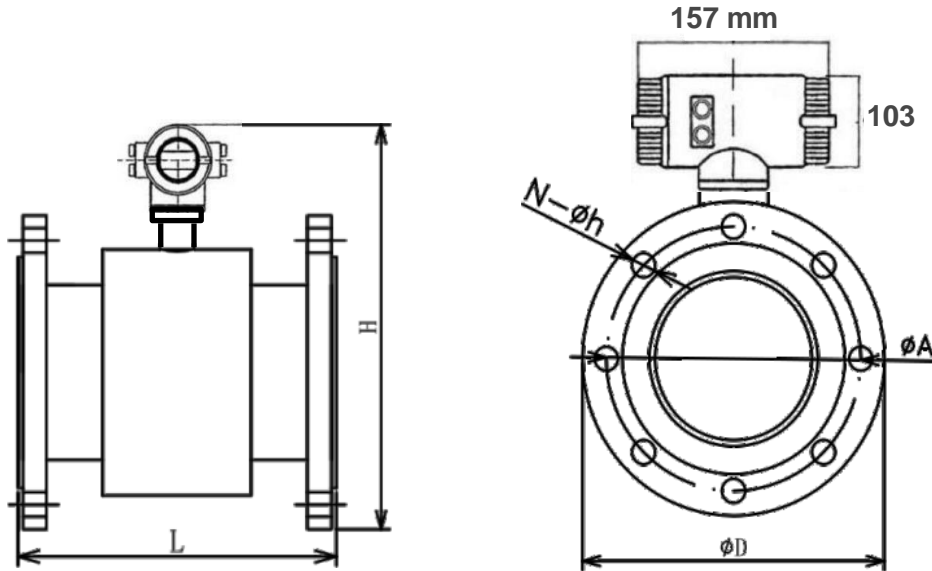

PIPE SIZE	L	D	A	N- Øh	H
DN 15	200	89	60.5	4-Ø15.7	248
DN20	200	99	69.9	4-Ø15.7	255
DN25	200	108	79.3	4-Ø15.7	264
DN32	200	118	88.9	4-Ø15.7	274
DN40	200	127	98.6	4-Ø15.7	282
DN50	200	152	120.7	4-Ø19.1	301
DN65	200	178	139.7	4-Ø19.1	321
DN80	200	190	152.4	4-Ø19.1	335
DN100	250	229	190.5	8-Ø19.1	366
DN125	250	254	215.9	8-Ø22.4	394
DN150	300	280	241.3	8-Ø22.4	420
DN200	350	343	298.5	8-Ø22.4	477
DN250	450	406	362	12-Ø25.4	546
DN300	500	483	432	12-Ø25.4	610
DN350	550	533	476	12-Ø28.4	619
DN400	600	597	540	16-Ø28.4	710



3.5 PREPARATIONS BEFORE OPERATION

- When the instrument is put into operation, follow the steps below:
- Open the front and rear valves of the sensor to fill the measuring tube with liquid;
- Check whether the output wiring of the converter and the power supply wiring are consistent with the corresponding wiring diagram;
- if there is a certain flow in the pipe, the converter should indicate a certain value;
- Adjust the zero position. After the instrument is powered on for half an hour, first close the downstream valve, and then close the upstream valve. When the fluid in the pipeline is still and there is no leakage, the flow is zero. If instructed, please refer to "Instrument
- Parameter Setting Flow Zero Correction" for the specific debugging method.



4 ELECTRICAL CONNECTIONS

4.1 SAFETY INSTRUCTIONS



DANGER!

Only when power is switched off, can we do all the work about electrical connections. Please pay all attention to the power supply on the name plate!



DANGER!

Observe the national regulations for electrical installations!



DANGER!

For devices used in hazardous areas, additional safety notes apply; please refer to the Ex documentation.



WARNING!

Observe without fail the local occupational health and safety regulations. Any work done on the electrical components of the measuring device may only be carried out by properly trained specialists.



INFORMATION!

Look at the device nameplate to ensure that the device is delivered according to your order. Check for the correct supply voltage printed on the nameplate.



INFORMATION!

Connect the cable on connector with similar numeral marking

4.2 CONNECT SIGNAL AND MAGNETIC FIELD CURRENT CABLE



Danger !

Only when power is cut off can you connect signal and magnetic field current conductor.



Danger !

The equipment must be grounded in accordance with regulations so as to protect the operator from electrical shock.



Danger !

In case that equipment be used in explosion danger areas, special notes are given to explosion-proof instructions for safety tips.



Warning !

Please strictly observe local occupational health and safety regulations. Only those who have got properly trained are allowed to operate on the electrical equipment

4.3 INSTRUMENT PARAMETER SETTING AND DESCRIPTION

DEFINITION OF LCD AND KEYBOARD

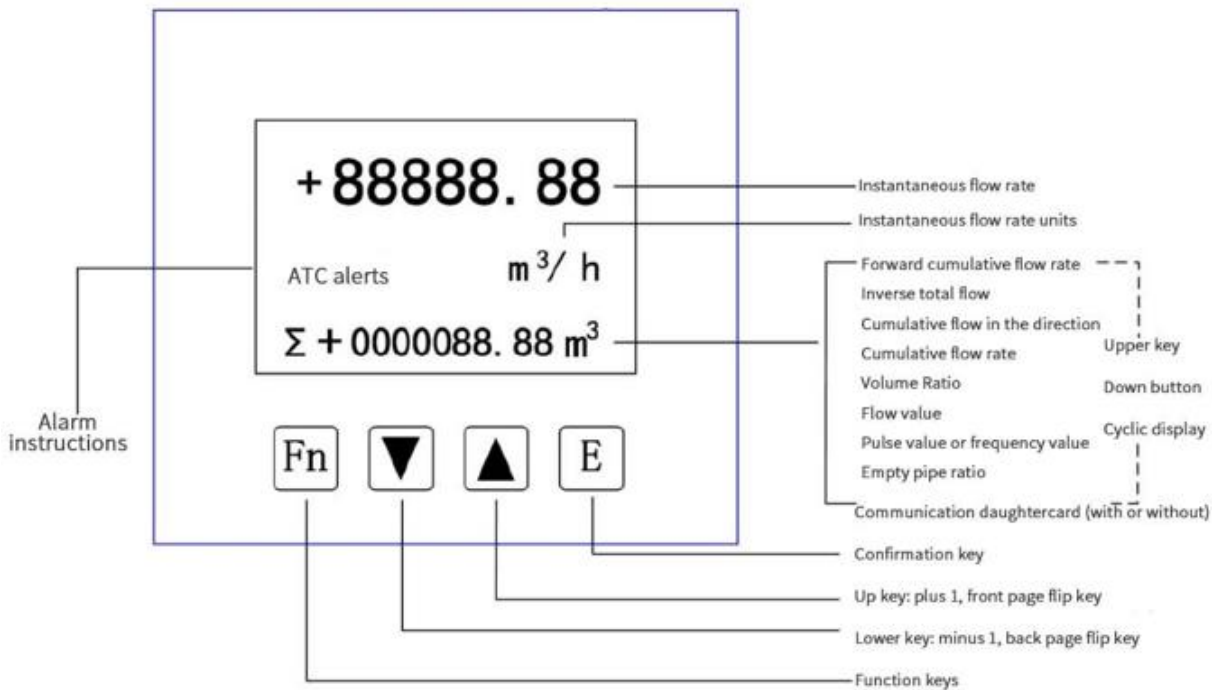

After the instrument is powered on, it enters the automatic measurement state, realizes various measurement functions and displays the corresponding measurement data. By operating the four panel keys, the instrument parameters can be set and displayed.

KEY FUNCTIONS

The instrument has four keys, which are function key, down key, up key, and exit key.

Up key: The number at the cursor is incremented by 1, and the content displayed on the upper line of the screen is cyclically selected. Down key: the number at the cursor is reduced by 1, and the content displayed in the lower part of the screen is cyclically selected. Function key: return to the previous menu, move the cursor to the right, cancel saving; enter the setting menu (in the main menu).

Function key + Up key: Increase LCD contrast (in the main menu). E Confirm key: Enter, confirm and save.

E Confirm key: Enter, confirm and save.



PASSWORD

The meter is designed with a 3-level password. Level 1 user password can modify the password value of this level; level 2 factory password modify the password of this level, and you can view the password value of level 1;

The user password is "90000", after entering the menu with the password, you can operate the corresponding password level, enter the password 90000, if it is correct, press the enter key to enter the menu, if the input is wrong or not, press the enter key to return to the main menu.



4.4 INSTRUMENT MENU

First-level Menu	Second-level Menu	Three-level Menu
Parameters Settings	Direction	Forward or reverse. Use this function if the traffic is installed in reverse
	Instrument range	0~99999m ³ /h (related to the frequency output of 4~20mA output)
	Unit of flow	L/h, L/m, L/s, m ³ /h, m ³ /m, m ³ /s, t/h, t/m, t/s, kg/h, kg/m, kg/s
	Decimal place settings for flow	Automatic, manual; when manually set, the instantaneous flow can be set to 0~3 decimal places
	Cumulative flow unit	0.001m ³ , 0.01m ³ , 0.1m ³ , 1m ³ , 0.001L, 0.01L, 0.1L, 1L, 1t, 1kg
	Cut-off point for small signal	Settings: Cut out small signal wobbles
	Damping time setting	The larger the display, the more stable the instantaneous flow and the larger the delay
	Liquid Density	Settings: Be sure to set density when using weight units
	Upper limit alarm value	Setting
	Lower limit alarm value	Setting
	Alarm hysteresis	Settings: Reasonable settings to prevent frequent actions
Function Setting	Reverse Measurement Allow	Off, On (default ' on')
Flow Query	Accumulation Total Reset	Yes, No
	Forward Accumulation Preset	Setting
	Reverse Accumulation Preset	Setting
Output Settings	Modbus settings	Device address, baud rate, parity bit, corresponding delay
	Pulse output mode	Pulse, frequency
	Pulse output setting	Pulse equivalent
	Frequency output settings	Frequency range
	Alarm output settings	Alarm output type selection
Diagnostic Tests	4-20mA output test	simulated current output
	Flow velocity test	simulating the flow status in the pipeline (frequency, pulse and current output)
	Pulse output test	simulate pulse output
	Frequency output test	simulate frequency output
Calibration Settings	Pipe setting	Diameter DN3~1000
	Flow zero point setting	Flow zero point correction, automatic zero point correction
	Sensor coefficient	Setting and sensor coefficient integration
System Settings	Factory reset	Yes/no
	LCD contrast	Setting
	LCD backlight time	Setting



4.5 WIRING DIAGRAM AND MODBUS REGISTER DETAI

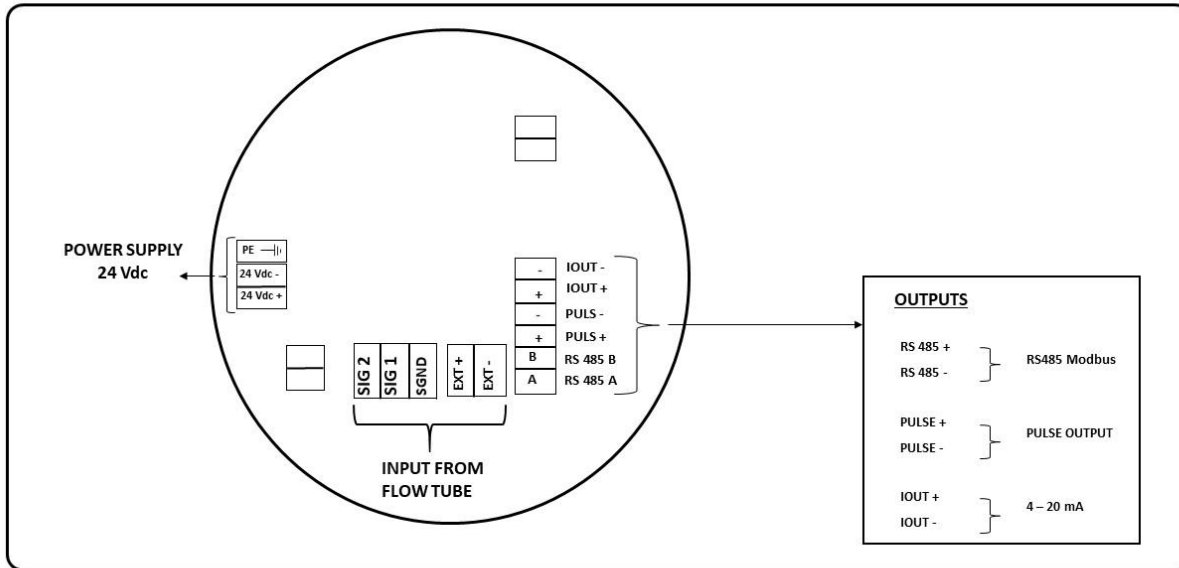

MEF 2100 C (Integral) Flow Meter MODBUS Configuration Details

4.6 MEF 2100 C MODBUS CONFIGURATION DETAILS OF FLOW METER TO BMS

Function Code	Details	Register Address	Modbus Register	Register Type
03 Holding Register	Flow Rate	01	40001	Swapped F.P
	Positive Total	05	40005	Swapped F.P
	Negative Total	07	40007	Swapped F.P
	Net Total	09	40009	Swapped F.P

Parity	: None
Word Length	: 8
Stop Bit	: 1

MEF 2100 C Flow Meter MODBUS Configuration Details

Note: If your BMS register address starts from '0', please decrement '1' value from every register. Example: Flow Rate register is 40002 then it should be configured as 40001.

4.7 CONNECTED TO POWER



It is mandatory to provide an individual 24 VDC, SMPS (Switch Mode Power Supply) for energizing the flow meters. Additionally, it is essential to pull three-core wires (DC+, DC-, and ground) for the 24 VDC input power supply. As these are electromagnetic flow meters, a proper input power supply with an appropriate ground is crucial for their correct operations



Danger !

The equipment must be grounded in accordance with regulations so as to protect the operator from electrical shock.



Don't use bolts that hold the pipes together to make electrical connections. These bolts might not connect well because of paint or grease. Instead, use the special earth connections on the flange.

LAYING ELECTRICAL CABLES CORRECTLY

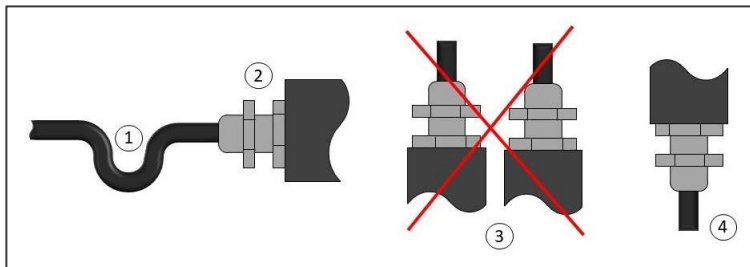

Keep the housing safe from dust and water

- i. Create a loop with the cable just before it reaches the housing.
- ii. Securely tighten the screw connection at the cable entry.
- iii. Always mount the housing with the cable entries facing downward.
- iv. Seal any unused cable entries with a plug.

4.8 EARTH CONNECTION



MEF 2100 C Flow meters detect small Electrical signals from electrodes when conductive fluid flows through their magnetic field, but electrical noise can interfere. To minimize noise, ensure the pipe, fluid, flow meter body, and transmitter are all connected to the same earth ground with the earth cable as short as possible.

①

Provide a quality Earth ground connection to the meter. From best to worst, grounding options include (stranded wire 14-18 AWG):

②

Earth grounding rod driven into the ground

③

Earth wire connected directly to the building electrical service panel ground.



4.9 FREQUENCY PULSE OUTPUT INTERFACE

Frequency output and pulse output share a set of terminals POUT (P+) and PCOM (P-), Select frequency or pulse output through the menu.

Frequency/pulse output supports three output modes.

OUTPUT MODE 1: OC GATE PASSIVE OUTPUT, PULL-UP RESISTOR CONNECTED TO THE USER SIDE.

The two-position DIP switch on the board of the split converter (the red DIP switch in the wiring cavity) is all turned outward (OFF position),

and the two on-board DIP switches of the integrated wiring board are all turned down (OFF position) .

POUT (P+) output frequency/pulse signal.

The external power supply V+ can be 5V/12V/24V, and the resistance value of the pull-up resistor R ranges from 2k to 10k.

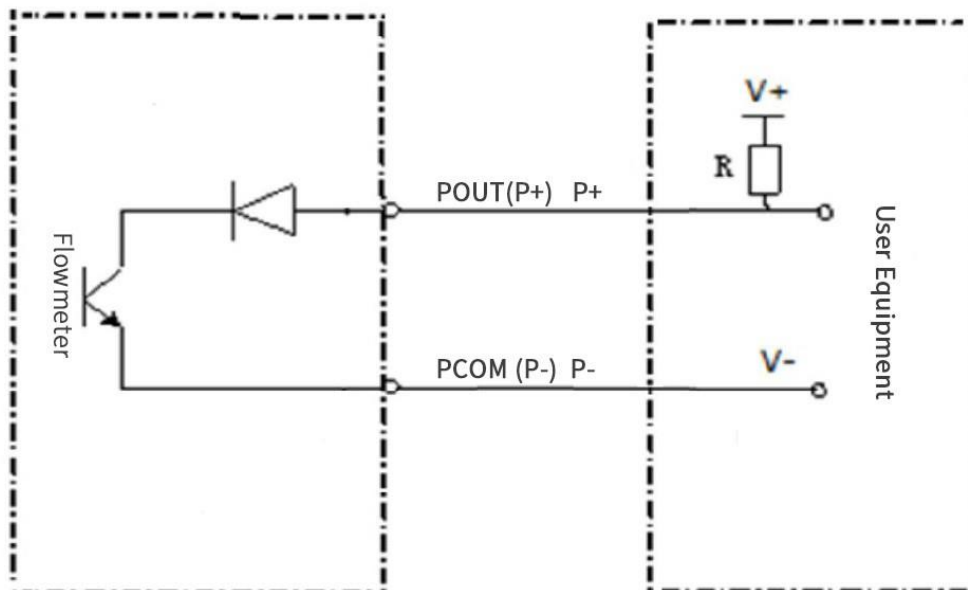

OUTPUT MODE 2: OC GATE PASSIVE OUTPUT, PULL-DOWN RESISTOR CONNECTED TO USER SIDE.

The two-position DIP switch on the board of the split converter (the red DIP switch in the wiring cavity) is all turned outward (OFF position),

and the two on-board DIP switches of the integrated wiring board are all turned down (OFF position) .

PCOM (P-) output frequency/pulse signal.

POUT (P+) is directly connected to the external power supply V+.



This mode is more common in the combined system of flowmeter and P

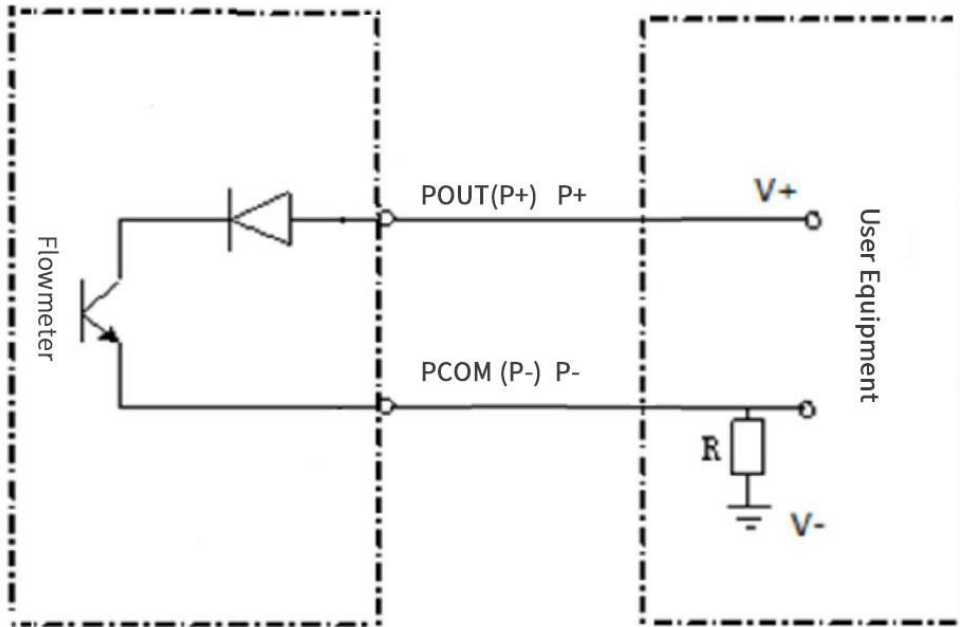

Output mode 3: Active output in level mode, which can directly drive the load.

The two-position DIP switch on the board of the split converter (the red DIP switch in the wiring cavity) is all turned inward (ON position),

and the two on-board DIP switches of the integrated wiring board are all turned up (ON position) .

POUT (P+) output frequency/pulse signal.

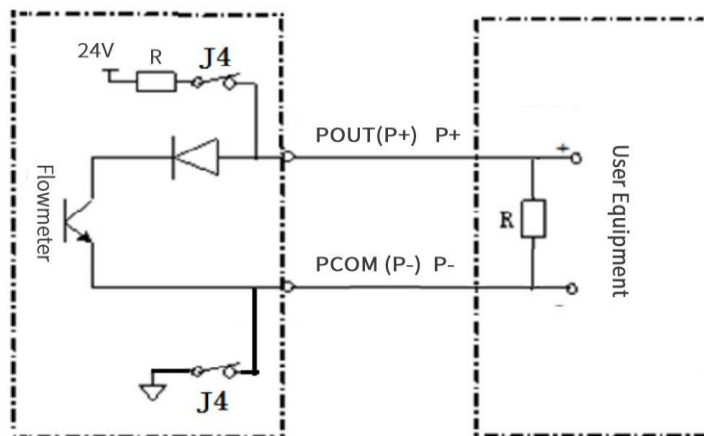



4.10 CURRENT OUTPUT INTERFACE

The current output is designed with a high-precision large-scale integrated circuit chip, without zero and full scale calibration, the output is stable and reliable, and has good interoperability and temperature stability.

The current output has three terminals IOUT(I+), ICOM(I-) and IVee, which support two current output modes:

Two-wire active current output and two-wire passive current output.

Output mode 1: two-wire active current output

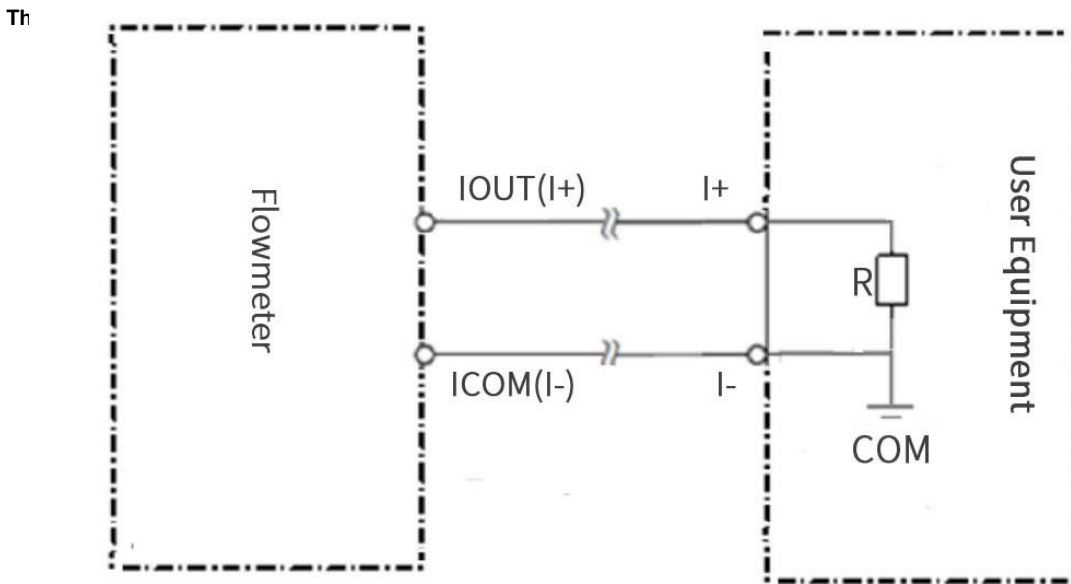

Output mode 2: two-wire passive current output

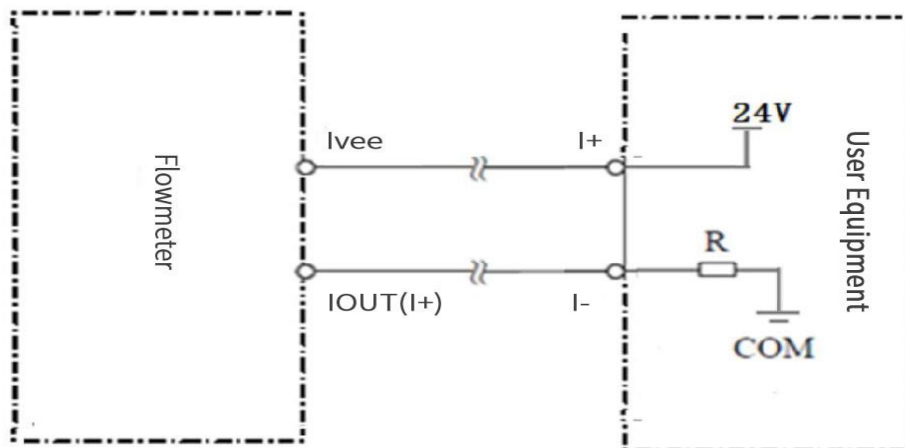

4.11 COMMUNICATION PROTOCOL

The converter supports standard RS-485 communication interface and ModBus communication protocol, which has been widely used as a system integration standard in domestic and foreign instrumentation industry and industrial control industry.

Information is transferred asynchronously and in bytes. Communication data (information frame) format

Data Format:	Address Code	Function Code	CRC Calibration
Data Length	1 Byte	1 Byte	16-bit CRC code (redundant cyclic code)

The protocol supports function codes 03 and 10. Function code 03 is used to read multiplex registers; function code 10 is used to write multiplex registers. This protocol supports reading common registers such as cumulative flow, and also supports reading and modification of instrument constants such as aperture zero sensor coefficients. At the same time, this protocol provides the function of clearing the accumulated amount, which is used for batch control and other control occasions. For details, please refer to the communication protocol specification. This manual only lists some commonly used registers.

The common register addresses of the flowmeter are defined as shown in the following table. (SF is single precision floating point format DW is long integer format W is integer format)

Register Address	Unit	Number of Bytes	Property	Format	Register Definition
4	Consistent with the display	4	RO	SF	Forward cumulative flow - floating point format
6	Consistent with the display	4	RO	SF	Reverse cumulative flow - floating point format
8	Consistent with the display	4	RO	SF	Total cumulative flow - floating point format
1030	Write 90900	4	RW	SF	Accumulated flow reset
0	Consistent with the display	4	RO	SF	Flow - floating point format
2	Consistent with the display	4	RO	SF	Flow rate - floating point format
4116	%	4	RO	SF	Flow Percentage - Float Format
112		2	RW	SF	Liquid density
4133		2	RO	SF	System alarm
4132		2	RO	SF	Empty pipeline alarm
128		2	RO	SF	Instrument alarm
106		4	RW	SF	Instantaneous flow unit



The flow unit values are as follows:

- 0: L/H 1: L/M 2: L/S 3: M³/H 4: M³/M 5: M³/S 6: KG/H
7: KG/M 8: KG/S 9: T/H 10: T/M 11: T/S

Communication protocol example description

Get the forward cumulant (floating point data format):

Register Address: 4 (0x04)

Host sent: 01 03 00 04 00 02 85 CA

Detailed description:

Data field	Byte count	Content sent	Annotation
Slave address	1	01	Slave address is 01
Function code	1	03	Read command
Register start address	2	00 04	Floating point format, the forward cumulant address is 0x0004
Register length	2	00 02	The cumulant is 32 bits and the length is two registers
CRC code	2	85 CA	CRC check code

high byte is ahead

Slave response: 01 03 04 40 A4 22 F8 B7 32

Detailed description:

Data field	Byte count	Content sent	Annotation
Slave address	1	01	Slave address is 01
Function code	1	03	Read command
Number of bytes returned	4	04	Two registers 4 bytes total
Register data 1	2	40 A4	Floating point format, forward cumulant, high 16 bits, high order first
Register data 2	2	22 F8	Floating point format, forward cumulant, low 16 bits, high order first

CRC code 2 B7 32 CRC check code high byte is ahead



Extended registers (compatible):			
Register Address	HEX	Type	Register Definition
4112	0x1010	Float	Instantaneous flow, floating point representation
4114	0x1012	Float	Instantaneous flow rate, floating point representation
4118	0x1016	Float	Fluid conductance ratio, floating point representation
4120	0x1018	Float	Positive cumulative value, integer part
4122	0x101A	Float	Positive cumulative value, fractional part
4124	0x101C	Float	Reverse cumulative value, integer part
4126	0x101E	Float	Reverse cumulative value, fractional part
4128	0x1020	Float	Unit of instantaneous flow
4129	0x1021	Float	Unit of cumulative total
4130	0x1022	Float	Upper limit alarm
4131	0x1023	Float	Lower limit alarm



APPENDIX 1: FLOW RANGE CHART

Unit:m3/h

Size (mm)	Flow Range & Velocity Table							
	0.1m/s	0.2m/s	0.5m/s	1m/s	4m/s	10m/s	12m/s	15m/s
3	0.003	0.005	0.013	0.025	0.102	0.254	0.305	0.382
6	0.01	0.020	0.051	0.102	0.407	1.017	1.221	1.526
10	0.028	0.057	0.141	0.283	1.130	2.826	3.391	4.239
15	0.064	0.127	0.318	0.636	2.543	6.359	7.630	9.538
20	0.113	0.226	0.565	1.130	4.522	11.304	13.56	16.956
25	0.177	0.353	0.883	1.766	7.065	17.663	21.2	26.494
32	0.289	0.579	1.447	2.894	11.575	28.938	34.73	43.407
40	0.452	0.904	2.261	4.522	18.086	45.216	54.26	67.824
50	0.707	1.413	3.533	7.065	28.260	70.650	84.78	105.98
65	1.19	2.39	5.97	11.94	47.76	119.40	143.3	179.10
80	1.81	3.62	9.04	18.09	72.35	180.86	217.0	271.30
100	2.83	5.65	14.13	28.26	113.04	282.60	339.1	423.90
125	4.42	8.83	22.08	44.16	176.63	441.56	529.9	662.34
150	6.36	12.72	31.79	63.59	254.34	635.85	763.0	953.78
200	11.3	22.61	56.52	113.04	452.16	1130.40	1356	1696
250	17.66	35.33	88.31	176.53	706.50	1766.25	2120	2649
300	25.43	50.87	127.2	254.34	1017	2543.40	3052	3815
350	34.62	69.24	173.1	346.19	1385	3461.85	4154	5193
400	45	90	226.1	452	1809	4522	5426	6782
450	57	114	286.1	572	2289	5723	6867	8584
500	71	141	353.3	707	2826	7065	8478	10598
600	102	203	508.7	1017	4069	10174	12208	15260
700	138	277	692.4	1385	5539	13847	16617	20771
800	181	362	904.3	1809	7235	18086	21704	27130
900	229	458	1145	2289	9156	22891	27469	34336
1000	283	565	1413	2826	11304	28260	33912	42390
1200	407	814	2035	4069	16278	40694	48833	61042
1400	554	1108	2769	5539	22156	55390	66468	83084
1600	723	1447	3617	7235	28938	72346	86815	108518
1800	916	1831	4578	9156	36625	91562	109875	137344
2000	1130	2261	5652	11304	45216	113040	135648	169560
2200	1368	2736	6839	13678	54711	136778	164134	205168
2400	1628	3256	8139	16278	65111	162778	195333	244166
2600	1910	3821	9552	19104	76415	191038	229245	286556
2800	2216	4431	11078	22156	88623	221558	265870	332338
3000	2543	5087	12717	25434	101736	254340	305208	381510

APPENDIX -II TROUBLESHOOTING OF THE INSTRUMENT

Fault Phenomenon	Possible Reasons	Check for Exclusions
There is liquid flowing through and the meter has no indication or no signal output	1. The power cord is not properly connected or the power circuit is faulty	Use a multimeter to check whether the power circuit is in good condition
	2. Failure of the connecting cable (excitation, signal circuit) system	Check whether the excitation and signal system cables are connected separately
	3. Failure in fluid flow condition	Check that the fluid flow direction matches the arrow on the sensor housing
	4. Damage to sensor parts	If the terminal is damp, dry it with a hair dryer to restore it
	5. The electrode surface is oxidized or has deposits	Remove the sensor to clean the electrode surface
	6. Converter failure	Check fuses, supply voltage, troubleshoot by substitution
The output signal is shaking	1. The fluid itself is fluctuating or pulsating or the process conditions themselves	Keep the sensor away from the pulsation source or install a buffer at the appropriate position in the pipeline to absorb pulse
	2. The pipeline is not filled with liquid or the liquid contains air bubbles	Retrofit the flowmeter to the correct installation location
	3. Interference from external stray currents, static electricity, electromagnetic waves and magnetic fields	To ensure a good ground condition, the resistance to ground is usually small
	4. When the liquid conductivity is uneven or the conductivity is too low; it contains more particles and fibers	Change the installation position; increase the excitation frequency
	5. The liquid does not match the electrode material	Change the electrode material of the sensor to match the liquid
Zero point is unstable	1. The pipeline is not filled with liquid or the liquid contains air bubbles; the process design of the pipeline network is poor or caused by related equipment	Retrofit the flowmeter to the correct installation location
	2. Subjectively think that there is no flow of liquid in the piping system, but there is actually a small flow	It is not the fault of the electromagnetic flowmeter, but it reflects the flow condition truthfully
	3. The grounding of the sensor is not perfect, and it is subject to external interference such as stray current	Improve the grounding condition, make the grounding resistance less than 10Ω
	4. The conductivity of the liquid varies or is uneven; the degree of contamination of the electrodes is inconsistent	The flow meter should be on the injection point or the chemical reaction section of the pipeline
	5. Signal line insulation drops	Replace the cable; do an insulation check on the sensor electrodes
The output signal is over full scale	1. There is no liquid communication between the electrodes, and interference is introduced from the liquid	Find a better installation location
	2. Poor grounding	Check the signal shield and ground point resistance, reinstall
	3. The cable is disconnected and the wiring is wrong	Rewire
	4. Converter and sensor matching error	Reset
Meter measured value does not match actual flow	1. The set value of the converter is incorrect	Review converter settings, check zero and span values
	2. The installation position of the sensor is incorrect, the tube is not full or there are air bubbles in the liquid	Check the technological process and improve the installation method
	3. Zero position change causes measurement error	Poor grounding or contaminated electrodes, check and eliminate it
	4. The value of the calibration coefficient of the converter is incorrect, and the flow condition upstream of the flowmeter	Re-adjusted according to the range calibration index value, and improved the flow process condition
	5. There are unknown branch pipes in the measurement system	
	6. Actual flow measurement method for comparison with electromagnetic flowmeters	Compare with standard flow meter



MIAL®
INSTRUMENTS PVT.LTD.
Measuring & Beyond

info@mialinstruments.com
+91 9913449547 | +91 9913449548

USA OFFICE : DOWNTOWN REPUBLIC CENTER , 325 N. ST.PAUL STREET, SUITE 3100,DALLAS 75201 ,TEXAS ,USA
FACTORY 1 : 856/6 GIDC MAKARPURA, VADODARA, GUJARAT-390010
FACTORY 2 : 0, 195, AATMIYA BROOKFIELDZ INDUSTRIAL PARK, POR, UNTIYA KAJAPUR, VADODARA, GUJARAT- 391243



www.mialinstruments.com