

| INSTALLATION & OPERATION MANUAL

MRL

Mial Radar Level Meter



MIAL[®]
INSTRUMENTS PVT. LTD.
Measuring & Beyond

www.mialinstruments.com

MRL

Mial Radar Level Meter

Preface

- Thank you for purchasing our product.
- This manual is about the various functions of the product, wiring methods, setting methods, operating methods, troubleshooting methods, etc.
- Please read this manual carefully before operation, use this product correctly to avoid unnecessary losses due to incorrect operation.
- After you finish reading, please keep it in a place where it can be easily accessed at any time for reference during operation.



NOTE!

Modification of this manual's contents will not be notified as a result of some factors, such as function upgrading. We try our best to guarantee that the manual content is accurate, if you find something wrong or incorrect, please contact us. The content of this manual is strictly prohibited from reprinting or copying.

About this manual

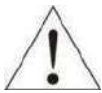
- Please submit this manual to the operator for reading.
- Please read the operation manual carefully before applying the instrument. On the precondition of full understanding.
- This manual only describes the functions of the product. The MIAL Instruments pvt.ltd. Does not guarantee that the product will be suitable for a particular use by the user.

Warnings and symbols used



HAZARD!

If not taken with appropriate precautions, will result in serious personal injury, product damage or major property damage.



WARNING!

Pay special attention to the important information linked to product or particular part in the operation Manual



CAUTION!

Disregarding these instructions can result in damage to the device or to parts of the operator's plant.



INFORMATION!

These instructions contain important information for the handling of the device.



Table of Contents

Preface.....	1
About this manual.....	1
1. INTRODUCTION.....	3
1.1 PURPOSE OF THE MANUAL	3
1.2 OPERATING PRINCIPLE	4
1.3 TECHNICAL SPECIFICATIONS.....	5
2 DEVICE DESCRIPTION	6
2.1 SCOPE OF DELIVERY.....	6
2.2 NAMEPLATE OF THE METER	6
2.3 DIMENSION FOR MRL.....	6
3 INSTALLATION GUIDE.....	8
3.1 LOCATION SELECTION.....	8
3.2 INSTALLATION MODE	9
3.3 INSTALLATION NOZZLE DIAGRAM.....	10
4 ELECTRICAL CONNECTIONS	12
4.1 SAFETY INSTRUCTIONS.....	12
4.2 WIRING.....	12
4.3 MRL Wiring Diagram	14
5 OPERATIONS	15
5.1 OPERATIONAL PANEL.....	15
5.2 Main INTERFACE	17
5.3 BASIC SETUP	18
5.4 Speciality setting.....	21
5.5 Message	31
5.6 Advances	32
Appendix-1 : Main Tree.....	35
Appendix -2 : Fault List	36
Appendix 3 : Modbus	37



1. INTRODUCTION

1.1 PURPOSE OF THE MANUAL

Overview:

Welcome to the user manual for the MRL Mial Radar Level Meter. This comprehensive guide is designed to assist operators, maintenance personnel, and system integrators in understanding, installing, operating, and maintaining the MRL Mial Radar Level Meter effectively.

Objectives:

Clarification of Functionality: This manual aims to provide a clear understanding of the principles and functionality of the MRL Mial Radar Level Meter. Users will gain insights into its design, components, and how it precisely measures fluid flow.

Guidance for Installation:

Step-by-step instructions and considerations for proper installation are provided to ensure optimal performance. Safety precautions are emphasized to create a secure working environment.

Training and Familiarization:

Users will be guided through the features, controls, and indicators of the flow meter, facilitating efficient operation. This section aims to serve as a valuable training resource for users at various experience levels.

Maintenance and Troubleshooting Assistance:

Learn about routine maintenance procedures and effective troubleshooting techniques. This manual empowers users to address common issues and perform regular maintenance to enhance the longevity of the Mial MRL.

Intended Audience:

This manual is intended for operators, maintenance personnel, and system integrators involved in the installation, operation, and maintenance of the MRL Mial Radar Level Meter . It is suitable for both novice users seeking basic guidance and experienced professionals looking for specific details.

Important Notes:

Please read through the manual carefully, adhering to safety guidelines and following instructions precisely. If any uncertainties arise during the installation, operation, or maintenance processes, seek assistance from qualified personnel or our customer service / support team.

Reference to Other Documentation:

Refer to the accompanying technical specifications document for in-depth details about the Mial Radar Level Meter . Additional resources can be found on our website.

Intended use



CAUTION!

Responsibility for the use of the measuring devices with regard to suitability, intended use and corrosion resistance of the used materials against the measured fluid lies solely with the operator.



INFORMATION!

The manufacturer is not liable for any damage resulting from improper use or use for other than the intended purpose

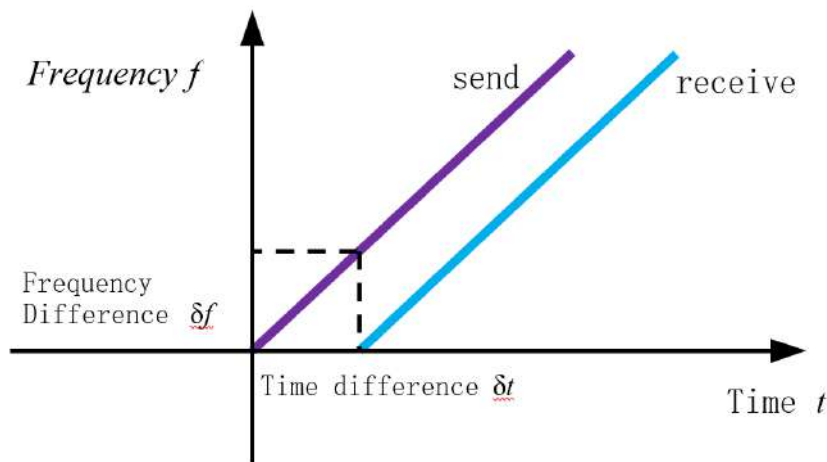


INFORMATION!

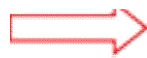
As the product is updated constantly, there is no guarantee the product specification and installation is fully consistent with the latest products. The part change contains but not limited to the following sections

1.2 OPERATING PRINCIPLE

The principle of FCM radar level meter is that the radar emits electromagnetic waves at the top of the tank, and the electromagnetic waves are received by the radar after they meet the medium reflection, and the frequency difference δf between the received signal and the transmitted signal is proportional to the distance R to the surface of the medium: $R = C \text{ (speed)} \cdot \delta f \text{ (frequency difference)} / 2/K \text{ (frequency modulation slope)}$. Because the speed of light C and the frequency slope K are known, the frequency difference δf can be calculated to obtain the distance R from the radar installation position to the material surface, and then subtract the space distance from the radar to the material surface by the known total height of the tank (referred to as the height of the air) to obtain the height of the material level materials.



Time difference $\delta t = 2R/C$



Distance $R = C \cdot \delta f / 2/K$

Frequency difference $\delta f = K \cdot \delta t$

Note: K is the frequency modulation slope

1.3 TECHNICAL SPECIFICATIONS

Measurement Principle

FMCW (Frequency Modulated Continuous Wave) Radar

Accuracy

±3mm

Resolution

1mm

Range

0-30m

Process Connection

Standard : Threaded (BSP 1 1/2")
Optional: Flanged (under DN 65)

Beam Angle

3° or 8°

Power supply range

24V DC

Use 2-amp SMPS when employing AC power

Electrical Interface

M20×1.5

Communication mode

MODBUS
HART

Outputs

2-wire 4~20mA +RS485

Cable inlet/plug

1 blind plugged M20×1.5
1 M20 XL.5 cable inlet

Frequency range

W-band [80 GHz]

Terminal

The cross section of the wire is 2.5mm²

Fault signal

The current output is unchanged ;
21mA ; 3.6mA

Integration time

(0 to 20)s, adjustable

Antenna form

Horn or lens antenna

Process pressure

-1 to 20 bar

Ambient storage temperature

-40~+80°C

Process temperature

Threaded or Flanged Under DN65 Ideally Do Not Reach Over 80°C
Data Will Drifting (Either Higher Or Lower).
Flanged Over DN65 Can Reach Under 200°C.

Process Connection

Standard :BSP 1 1/2", BSP 3 1/2",
Optional : Flange DN40-DN200 (Universal Flange Could Do DN250)

Materials

Enclosure : Cast Aluminum Alloy
Threaded : (Standard -PTFE) / (Optional -SS304)
Flange : (Standard -PTFE) / (Optional - SS304)

Shell

Standard: Cast aluminum
Optional: Stainless steel

Seal between housing and housing

Silicone rubber

Shell window

Polycarbonate

Ground terminal

Stainless Steel

Blind Zone

Depending On Low Level

Blind zone is 0.15 meter for the sensors
having capacity of 30 m measuring
range.

*Adjustments
Install Height Under 20m Barely No Blind Zone (Normally there is a fix tube for flange
install at least 0.3m around already.)*

Adjustment time

About 1 second (depends on parameter Settings)

Relative humidity

< 95%

Shock-proof

Mechanical vibration 10m/s², (10 ~ 150)Hz

Class of protection

Display Head IP65, Probe IP68.

*Specifications are subject to change without prior notice



2. DEVICE DESCRIPTION

2.1 SCOPE OF DELIVERY



INFORMATION!

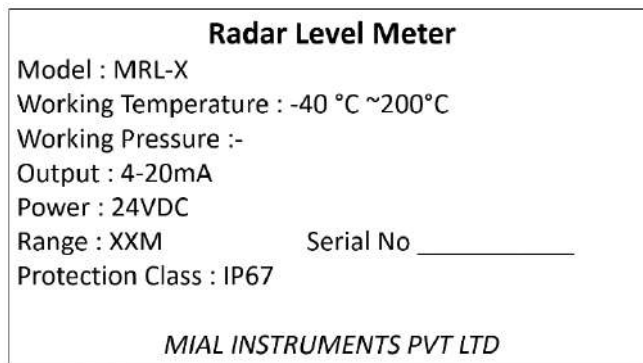
Do a check of the packing list to make sure that you have all the elements given in the order



INFORMATION!

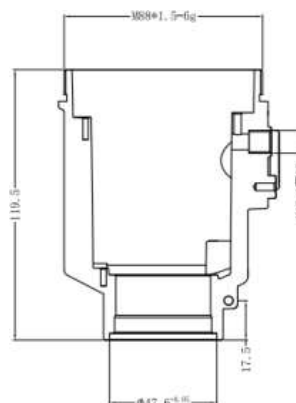
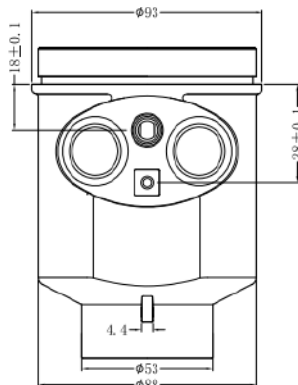
Inspect the packaging carefully for damages or signs of rough handling. Report damage to the carrier and to the local office of the manufacturer.

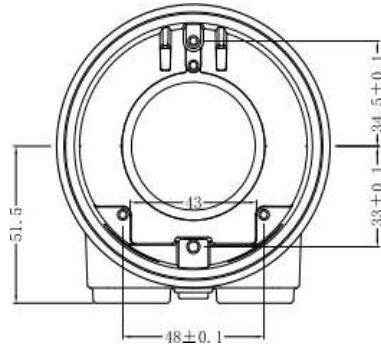
2.2 NAMEPLATE OF THE METER



2.3 DIMENSION FOR MRL LEVEL SENSOR

2.3.1 CASE SIZE

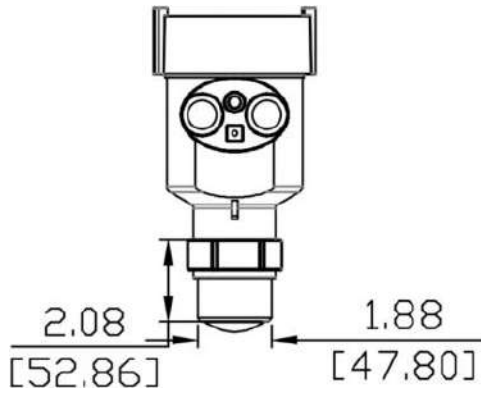




2.3.2 ANTENNA SIZE

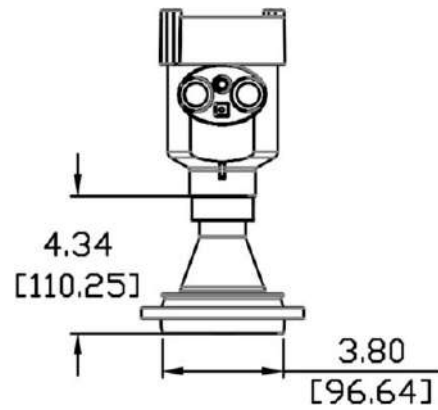


Figure 9



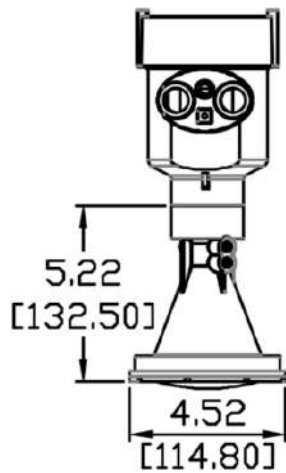
G1 1/2 Threaded antenna size

Figure 10



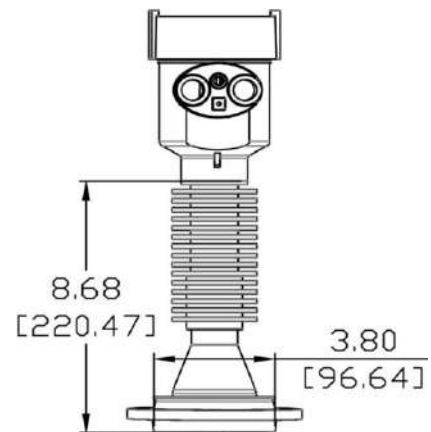
Dimensions of the cardan horn lens antenna

Figure 11



Fixed direction horn lens antenna size

Figure 12



High temperature cardan horn lens antenna dimensions

Figure 13



3. INSTALLATION

3.1 LOCATION SELECTION

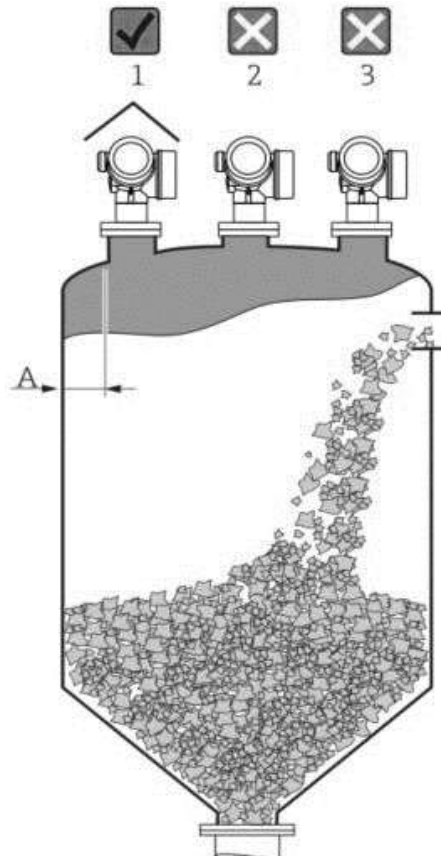


Figure 1

The recommended distance A (the distance between the tank wall and the outer wall of the mounted pipe) is approximately $1/6$ of the diameter of the tank, but the distance between the installed equipment and the tank wall should always be greater than 20 cm (7.87 in).

If the tank walls are not smooth (corrugated steel, welds, joints, etc.), it is recommended to install the equipment as far away from the tank walls as possible. If necessary, the antenna Angle adjustment device can be used for installation to avoid interference reflection from the tank wall.

It is not recommended to install the device in the center of the tank (2), as interference can cause signal loss.

Do not install the equipment above the feed port (3).



3.2 INSTALLATION MODE

❖ Installation method 1: threaded installation

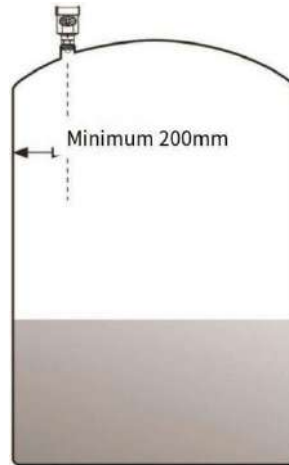


Figure 2

❖ Installation method 2: Flange installation

The minimum distance between instrument and tank wall should be 200mm when flange installation is adopted.

① datum surface

② Center of container or axis of symmetry

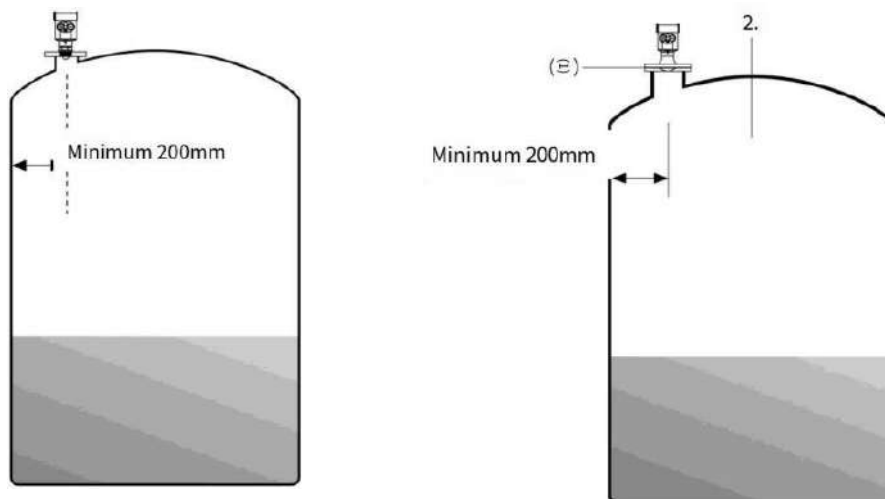


Figure 3



❖ Installation method 3: hoisting (selected according to the specific installation conditions)

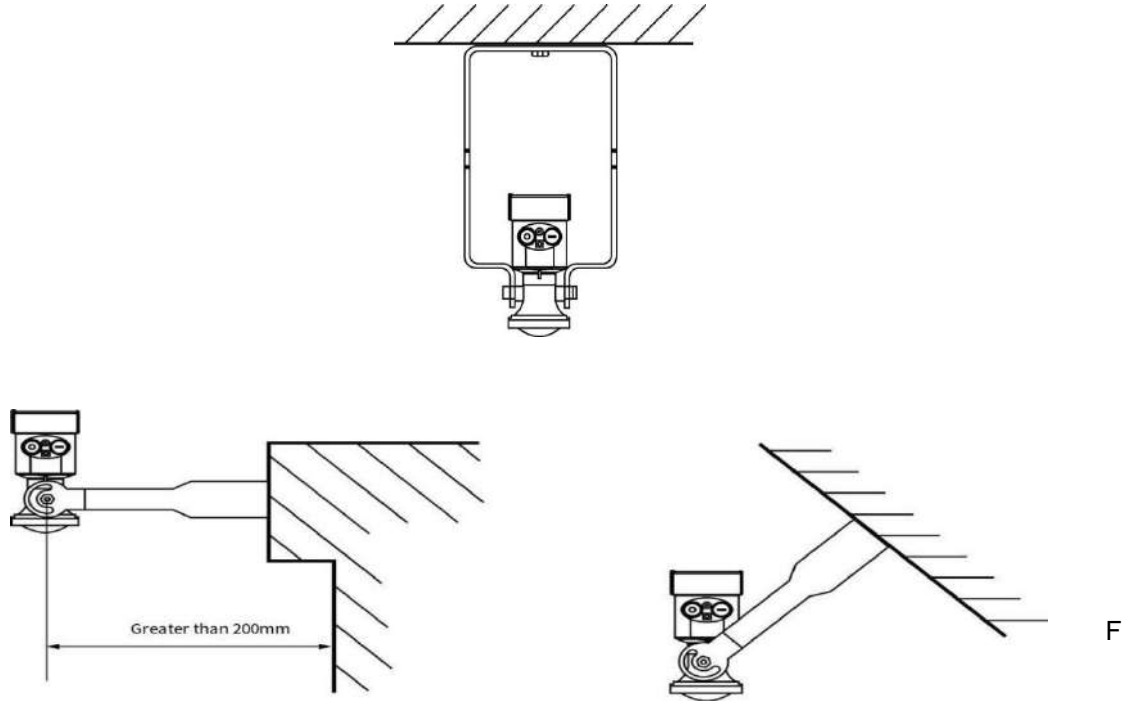


Figure 4

3.3 INSTALLATION NOZZLE DIAGRAM:

The maximum height of H max depends on the diameter of D and the emission angle of the product. Too long the installation and takeover will affect the radar performance.

- 1.5-inch antenna, 8 emission Angle

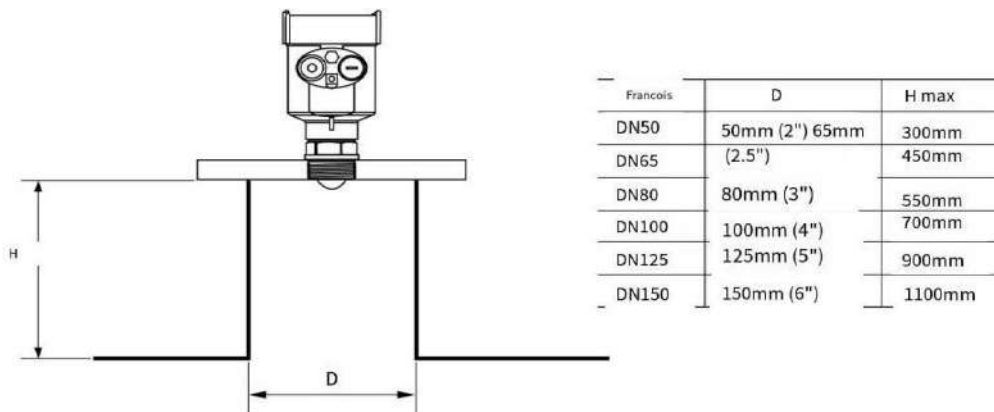
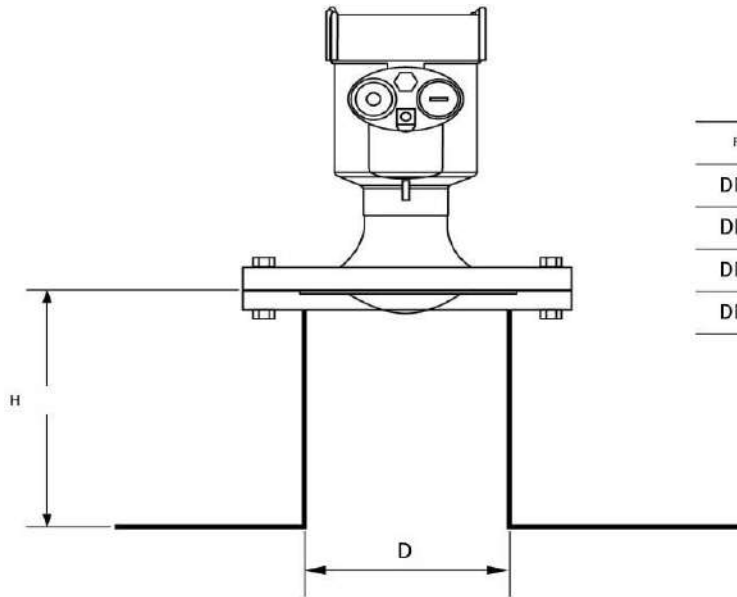


Figure 5



- 3.5-inch antenna 3° transmission Angle



Francois	D	H max
DN80	80mm (3")	1200mm
DN100	100mm (4")	1500mm
DN125	125mm (5")	2000mm
DN150	150mm (6")	2500mm

Figure 6



4 ELECTRICAL CONNECTIONS

4.1 SAFETY INSTRUCTIONS



DANGER!

Only when power is switched off, can we do all the work about electrical connections. Please pay all attention to the power supply on the name plate!



DANGER!

Observe the national regulations for electrical installations!



DANGER!

For devices used in hazardous areas, additional safety notes apply; please refer to the Ex documentation.



WARNING!

Observe without fail the local occupational health and safety regulations. Any work done on the electrical components of the measuring device may only be carried out by properly trained specialists.



INFORMATION!

Look at the device nameplate to ensure that the device is delivered according to your order. Check for the correct supply voltage printed on the nameplate.



INFORMATION!

Connect the cable on connector with similar numeral marking

4.2 WIRING

❖ **Supply voltage**

(4~20) mA / HART / $24 \pm 6V$ (two-wire system): the power supply and the output current signal share a two-core shielded cable.

❖ **Attended mode**

➤ 24V The two-wire system wiring diagram is as follow:

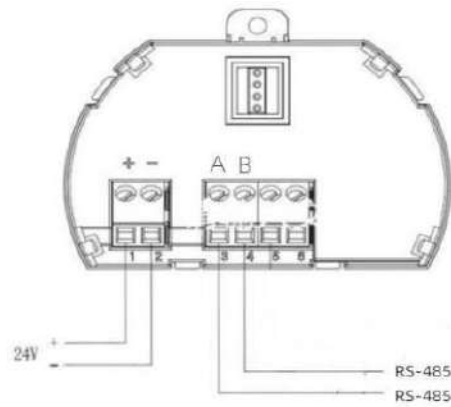


Figure 7

❖ Safety guidance

Please follow the local regulatory requirements for personnel health and safety. All operation of instrument electrical components must be performed by properly trained professionals.

Please check the nameplate of the instrument to ensure that the product specifications meet your requirements.

Please ensure that the power supply voltage is consistent with the requirements on the instrument nameplate.

❖ Levels of protection

This instrument fully meets the requirements of the protection grade IP66 / 67, please ensure the water resistance of the cable sealing head, as illustrated in following figure:

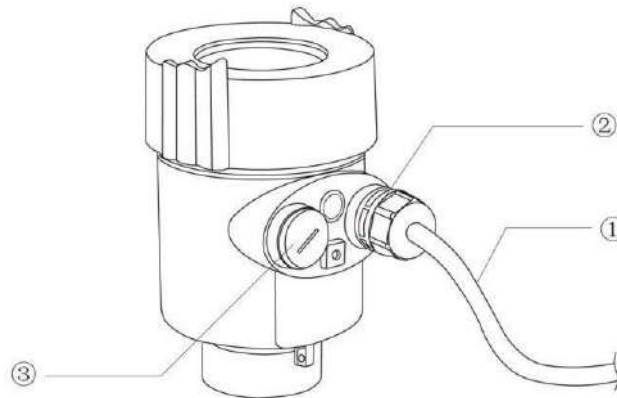


Figure 8

How to ensure that the installation meets the IP67 requirements: Please ensure that the seal head is not damaged.

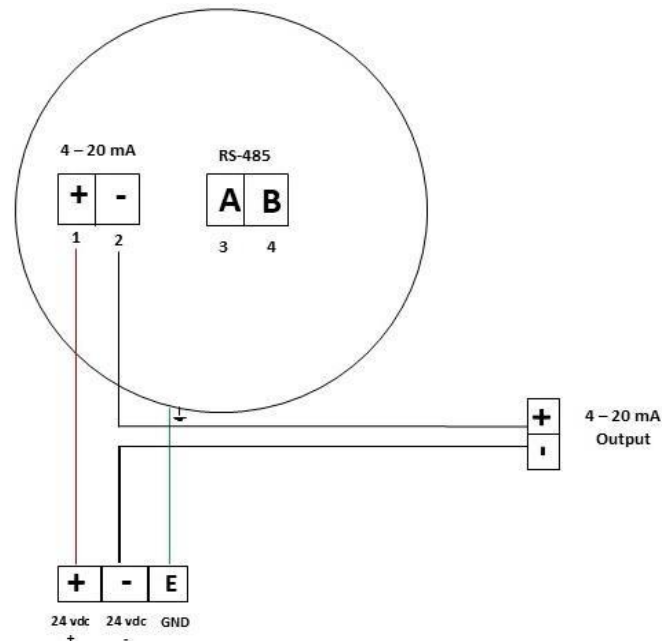
Please ensure that the cable is not damaged.

Ensure that the cables used meet the electrical connection specification.

Before entering the electrical interface, bend the cable down to ensure that the water does not flow into the housing, see (1) Tighten the cable seal head, see (2)

Please blind the unused electrical interface, see (3)

4.3 Mial Radar Level Meter Wiring Diagram



MRL MODBUS Configuration details of Level meter to BMS

Function Code	Details	Register Address	Modbus Register	Register Type
03: Holding Register	Distance	0001	40001	Swapped Floating Point
	Level	0003	40003	Swapped Floating Point
	Percentage	0005	40005	Swapped Floating Point
	mA Value	0007	40007	Swapped Floating Point

Parity	: None
Word Length	: 8
Stop Bit	: 1

Note: If your BMS register address starts from '0', please decrement '1' value from every register. Example: Flow rate register is 40000 then it should be configured as 40001.

5. OPERATIONS

5.1 DEBUG WITH DISPLAY AND ADJUSTMENT MODULES

5.1.1 OPERATION PANEL

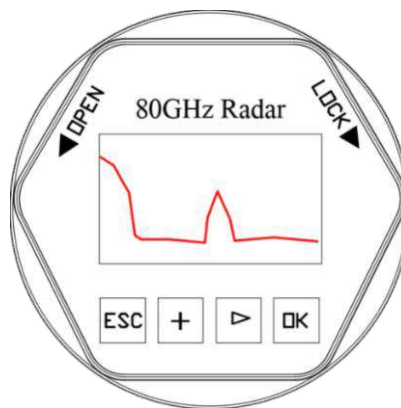


Figure14 Field display and adjustment module

❖ KEY FUNCTION

Keyname	Keyfunction
[ESC]	<ul style="list-style-type: none"> ● exit input ● Jump back to the previous menu ● Shortcut keys switch between the echo curve interface and the main interface
[+]	<ul style="list-style-type: none"> ● Changes the parameter value ● Shortcut key to switch the main interface display value empty height/material height/current
[▶]	<ul style="list-style-type: none"> ● Replace the display of the measured value ● Select the entry in the list ● Select the menu item ● Select the edit location ● Shortcut key Echo curve screen: Show or hide the envelope ● Shortcut key Main screen: Displays the current setting parameters and running time



【OK】	<ul style="list-style-type: none">● Switch to Menu Overview● Confirm the selected menu● Edit parameters● Stored value
------	--

Note: Press ESC and OK keys at the same time to restart the device for 5s

5.2 MAIN INTERFACE

❖ MAIN INTERFACE

The running screen is the first screen after the device is powered on, that is, the main screen

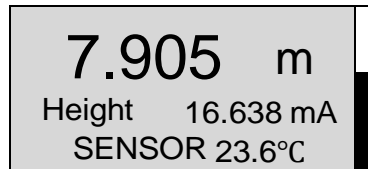


Figure 15 Main interface

- 7.905, indicates the current measured value
- Height, Indicates that the current measured value is the material level height
- sensor, Indicating sensor tag
- 23.6°C, Indicating current temperature
- M, Indicates the current unit of measurement

❖ ECHO CURVE

On the home screen, press [ESC] to enter the echo curve screen.

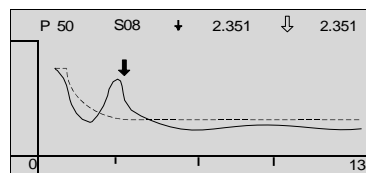


Figure 16 Echo curve

- P, indicates echo power; S, signal-to-noise ratio
- The solid arrow and hollow arrow indicate the current real-time measurement distance and the output distance of the main interface, respectively
- 13, indicating the horizontal coordinate measurement range

5.3 BASIC SETUP

On the home screen, press [OK] to enter the main menu.

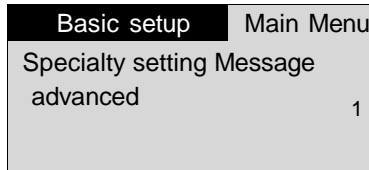


Figure 17 Basic setup

- Basic Settings: General Settings for parameter Settings
- Professional Settings: Radar output characteristic Settings
- Information: Hardware and software models delivered by the device
- Advanced: Upgrade the device and restore factory Settings

SENSOR TAG

The figure shows the interface diagram of the sensor label.

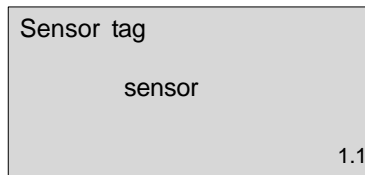


Figure 18 Sensor tag

- Location: General 1.1 TAB
- Function: In multiple radar equipment, mark each radar number to distinguish; The device's Bluetooth name and HART operator read name
- Use: type [OK] to operate and confirm, type [+] to set the value size, type [▶] to select the edit location

❖ APPLICATION SCENARIO

The interface diagram of the application scenario is shown in the figure.

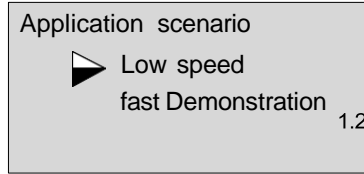


Figure 19 Application scenario

- Location: General 1.2 TAB
- Function: Set the radar application scenario
- Use: Type [OK] to operate and confirm, type [▶] select

MEDIUM TYPE

- The interface diagram of media type is shown in the figure.

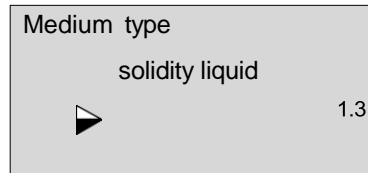


Figure 20 Medium type

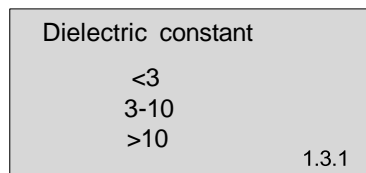


Figure 21 Dielectric constant

- Location: General 1.3 TAB
- Function: Set radar to measure medium type and corresponding dielectric constant
- Use: Type [OK] to operate and confirm, type [▶] select

LEVEL ADJUSTMENT

- The figure shows the interface diagram of material level adjustment.

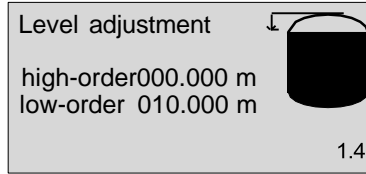


Figure 22 Level adjustment

- Location: General 1.4 TAB
- Action: distance and 4...20mA current mapping
- Use: type [OK] to operate and confirm, type [+] to set the value size, type [▶] to select the edit location

MEASURING RANGE

The interface diagram of the measurement range is shown in the figure.

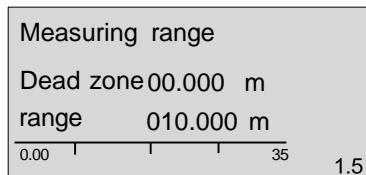


Figure 23 Measurement range

- Location: General 1.5 TAB
- Function: Set the radar measurement farthest distance and minimum blind area
- Use: type [OK] to operate and confirm, type [+] to set the value size, type [▶] to select the edit location

DAMPING

- The damping interface diagram is shown in the figure.

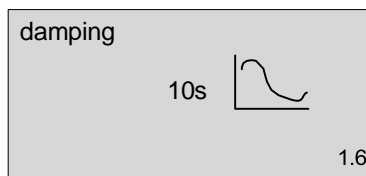


Figure 24 Damping



- Location: General 1.6 TAB
- Function: The output of the measured value is smoother, the larger the value, the smoother
- Use: type [OK] to operate and confirm, type [+] to set the value size, type [] to select the edit location

5.4 SPECIALTY SETTING

❖ DEBUG

❖ ECHO CURVE

The interface diagram of echo curve is shown in the figure.

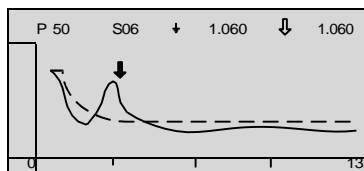


Figure 25 Echo curve

- Location: General 2.1.1 TAB
- Function: View the current echo curve

❖ HISTORICAL CURVE

The interface diagram of the historical curve is shown in the figure.

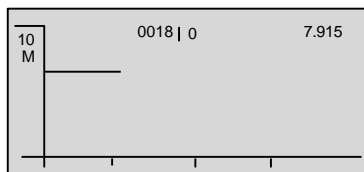


Figure 26 Historical curve

- Location: General 2.1.2 TAB
- Function: View historical measurements

❖ **FAULT LIST**

The fault list interface is shown in the figure.

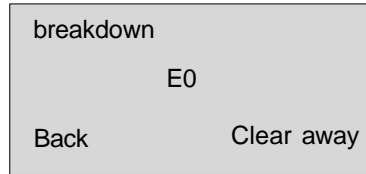


Figure 27 Fault list

- Location: General 2.1.3 TAB
- Function: View historical device faults
- Fault code: See attached fault code

❖ **ECHO DIAGNOSIS**

The figure shows the interface diagram of echo diagnosis.

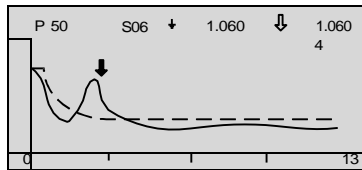


Figure 28 Echo diagnosis

- Location: General 2.1.4 TAB
- Function: View historical fault echoes of the device

❖ **SETTINGS**

❖ **CURRENT MODE**

- characteristic curve
- The figure shows the interface diagram of the characteristic curve in the current mode.

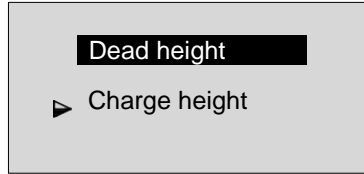


Figure 29 Characteristic curve

- Location: General 2.2.1.1 TAB
- Function: The maximum set point and minimum set point map with the current. As shown above, the maximum set point corresponds to 20mA and the minimum set point corresponds to 4mA
- Use: Type [OK] to operate and confirm, type [▶] select
- Fault mode

The fault mode interface diagram in current mode is shown in the figure.

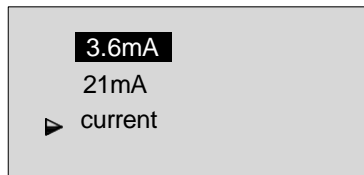


Figure 30 Failure mode

- Location: General 2.2.1.2 TAB
- Action: The output mode of the current when an error occurs in the device, options as shown above indicate that the current remains at the current value when the device fails
- Use: Type [OK] to operate and confirm, type [▶] select

➤ **MINIMUM CURRENT**

The figure shows the minimum current interface diagram in the current mode.



Figure 31 Minimum current

- Location: General 2.2.1.3 TAB

- Function: Indicates the minimum current that the device can output
- Use: Type [OK] to operate and confirm, type [▶] select

➤ MAXIMUM CURRENT

The figure shows the maximum current interface in the current mode.



Figure 32 Maximum current

- Location: General 2.2.1.4 TAB
- Function: Indicates the maximum current that the device can output.
- Use: Type [OK] to operate and confirm, type [▶] select

❖ OFFSET CORRECTION

The interface diagram for offset correction is shown in the figure.

Actual material height	<u>07.989</u> m
Material height difference	+ 00.000 m
Current shift	+ 0.000

Figure 33 Offset correction

Location: General 2.2.2 TAB

Function: Calibrate the fixed deviation of the measured distance and the current deviation

Use: type [OK] to operate and confirm, type [+] to set the value size, type [▶] to select the edit location

❖ SPURIOUS ECHO

The interface diagram of false echo is shown in the figure.

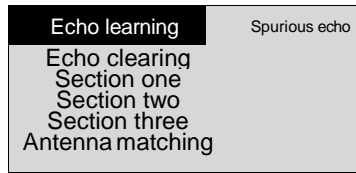


Figure 34 False echoes

- Location: General 2.2.3 TAB
- Function: false echo learning is carried out when there are interference echoes that need to be shielded
- Use: Type [OK] to operate and confirm, type [▶] select
- First choose to study back in wave, yes
- Then set zone 1, Zone 2, and zone 3 according to the false echo position
- antenna matching is mainly used to match different antennas before the radar is delivered

❖ CURRENT CALIBRATION

The interface diagram of current calibration is shown in the figure.

▶ 4mA Actual measurement	00.000
20mA Actual measurement	00.000
Loop test	00.000

Figure 35 Current calibration

- Location: General 2.2.4 TAB
- Function: Calibrate 20mA, 4mA fixed deviation by simulation current
- Use: type [OK] to operate and confirm, type [+] to set the value size, type [▶] to select the edit location

❖ LANGUAGE

The figure is shown as the language interface diagram.



Figure 36 Language

- Location: General 2.2.5 TAB
- Function: Menu languages, including simplified Chinese and English
- Use: Type [OK] to operate and confirm, type [▶] select

❖ REVEAL

As shown in the figure is the display interface diagram

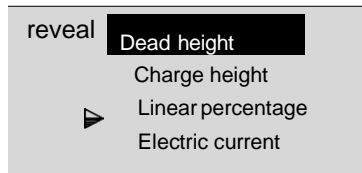


Figure 37 shows

- Location: General 2.2.6 TAB
- Function: The value meaning is displayed on the main interface. The default value is material height
- Use: Type [OK] to operate and confirm, type [▶] select

❖ UNIT

The figure shows the unit interface diagram.

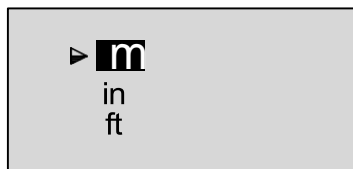


Figure 38 Units

- Location: General 2.2.7 TAB
- Function: Unit of measurement, including meters, inches, feet
- Use: Type [OK] to operate and confirm, type [▶] select

❖ CONTRAST

The contrast interface is shown in the figure.

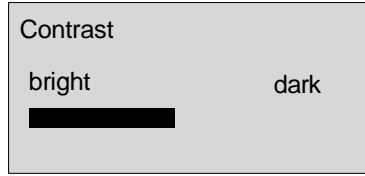


Figure 39 Contrast

- Location: General 2.2.8 TAB
- Action: Select the appropriate contrast by adjusting the light/dark
- To use: Type [OK] to operate and confirm, type [+] to lighten, type [▶] to darken

❖ EXPERT

The figure shows the expert interface diagram.

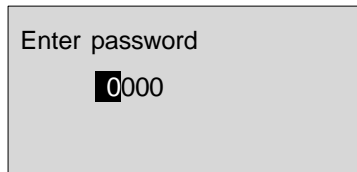


Figure 40 Experts

❖ GAIN ADJUSTMENT

The gain adjustment interface is shown in the figure.

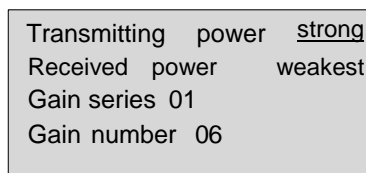


Figure 41 Gain adjustment

- Location: General 2.3.1 TAB
- Function: Adjust the power according to the actual scenario

- Use: type [OK] to operate and confirm, type [+] to set the value size, type [▶] to select the edit location

❖ ENVELOPE

The figure shows the interface diagram of the envelope line.

```
Envelope line
type 0
weight 02.00dB
Similarity 40 %
Threshold value 50dB
lock 05dB
```

Figure 42 Envelope

- Location: General 2.3.2 TAB
- Function: Envelope type 0, that is, the radar automatically calculates the envelope parameters, when the overall need to raise or lower the envelope, adjust the weight can be
- Use: type [OK] to operate and confirm, type [+] to set the value size, type [▶] to select the edit location

❖ ECHO SIGNAL

The interface diagram of echo signal is shown in the figure.

```
▶ Echo signal
Maximum wave ▶ Highly refined
First good wave non-high
Last good wave Auto
```

Figure 43 Echo signal

- Location: General 2.3.3 TAB
- Function: Select the specific echo signal according to the actual situation on site
- Use: Type [OK] to operate and confirm, type [▶] select



❖ MATERIAL VELOCITY

The interface diagram of material velocity is shown in the figure.

```
speed 06 time  
radius 00.30 m time  
01 min 00s  
tendency 01 min 00s
```

Figure 44 Material velocity

- Location: General 2.3.4 TAB
- Function: The output of measured values is smoother by adjusting the material speed
- Use: type [OK] to operate and confirm, type [+] to set the value size, type [▢] to select the edit location

❖ ZERO CALIBRATION

The interface diagram for zero calibration is shown in the figure.

```
Zero calibration amend  
02.089 m  
skew 0.220 m
```

Figure 45 Zero calibration

- Location: General 2.3.5 TAB
- Function: Calibrate zero point before leaving the factory
- Use: type [OK] to operate and confirm, type [+] to set the value size, type [▢] to select the edit location

❖ RANGE CALIBRATION

The interface diagram of distance calibration is shown in the figure.

0	P1	0
Measured value	0	0
Reference value	0	0
resetting		

Figure 46 Distance calibration

- Location: General 2.3.6 TAB
- Function: Calibrate the measuring distance in the actual measurement
- Use: type [OK] to operate and confirm, type [+] to set the value size, type [▶] to select the edit location

❖ BAUD RATE

Thebaudrateinterfaceisshowninthefigure.

Baud rate	115200
	38400
	▶ 9600
	4800

Figure 47 Baud rate

- Location: General 2.3.7 TAB
- Function: Transfer rate during communication. The default is 9600
- Use: Type [OK] to operate and confirm, type [▶] select

❖ MEASURING INTERVAL

Theinterface diagram of measurement interval is shown in the figure.

Measuring interval <u>A</u>
00m 00s 300ms
Record interval 120s

Figure 48 Measurement interval

- Location: General 2.3.8 TAB
- Function: Adjust the measurement interval and historical data recording interval by changing the parameters

- Use: type [OK] to operate and confirm, type [+] to set the value size, type [] to select the edit location

5.5 MESSAGE

❖ INSTRUMENT NAME

- The interface diagram of instrument name is shown in the figure.

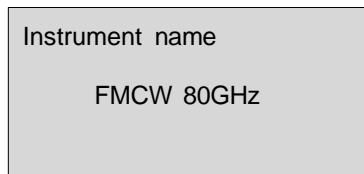


Figure 49 Instrument name

- Location: General 3.1 TAB

❖ INSTRUMENT VERSION

The interface diagram of instrument version is shown in the figure.



Figure 50 Instrument version

- Location: General 3.2 TAB

❖ OTHER

Other interface diagrams are shown in the figure.

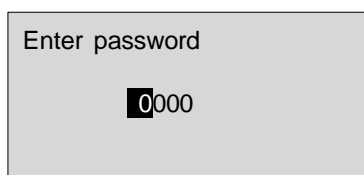


Figure 51 Others

- Location: General 3.3 TAB
- Function: Reserve the menu
- Use: type [OK] to operate and confirm, type [+] to set the value size, type [▶] to select the edit location

5.6 ADVANCED

❖ FACTORY RECOVERY

As shown in the figure, the factory interface is restored.

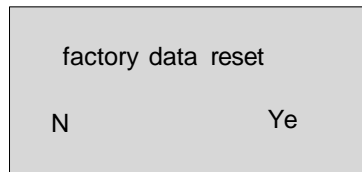


Figure 52 Factory restoration

- Location: General 4.1 TAB
- Function: Restore the device parameters to default factory values
- Use: Type [OK] to operate and confirm

❖ PARAMETER BACKUP

The figure shows the parameter backup interface.

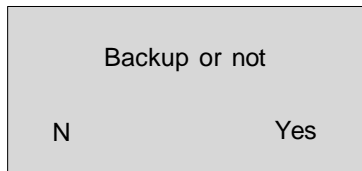


Figure 53 Parameter backup

- Location: General 4.2 TAB
- Function: Backs up the existing Settings
- Use: Type [OK] to operate and confirm

❖ RESTORE BACKUP

The following figure shows the backup restoration interface.

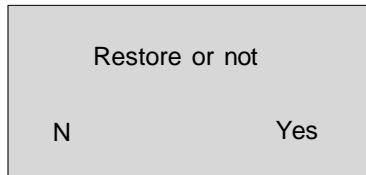


Figure 54 Restoring the backup

- Location: General 4.3 TAB
- Function: Restore backup parameters
- Use: Type [OK] to operate and confirm

❖ MODBUS ADDRESS

The Modbus address interface is shown in the figure.

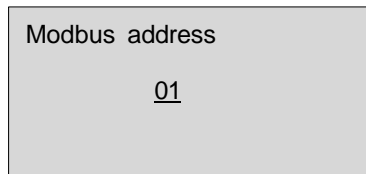


Figure 55 MODBUS address

- Location: General 4.4 TAB
- Function: Address used for communication over MODBUS
- Use: type [OK] to operate and confirm, type [+] to set the value size, type [▶] to select the edit location

❖ DIELECTRIC MATCHING

The interface diagram of media matching is shown in the figure.

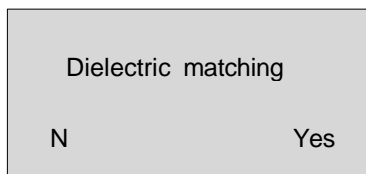


Figure 58 Media matching

- Location: General 4.7 TAB
- Function: Match suitable media type and dielectric constant for different measured media

❖ BLUETOOTH PASSWORD

The picture shown is the Bluetooth password interface diagram.

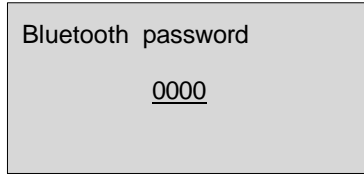
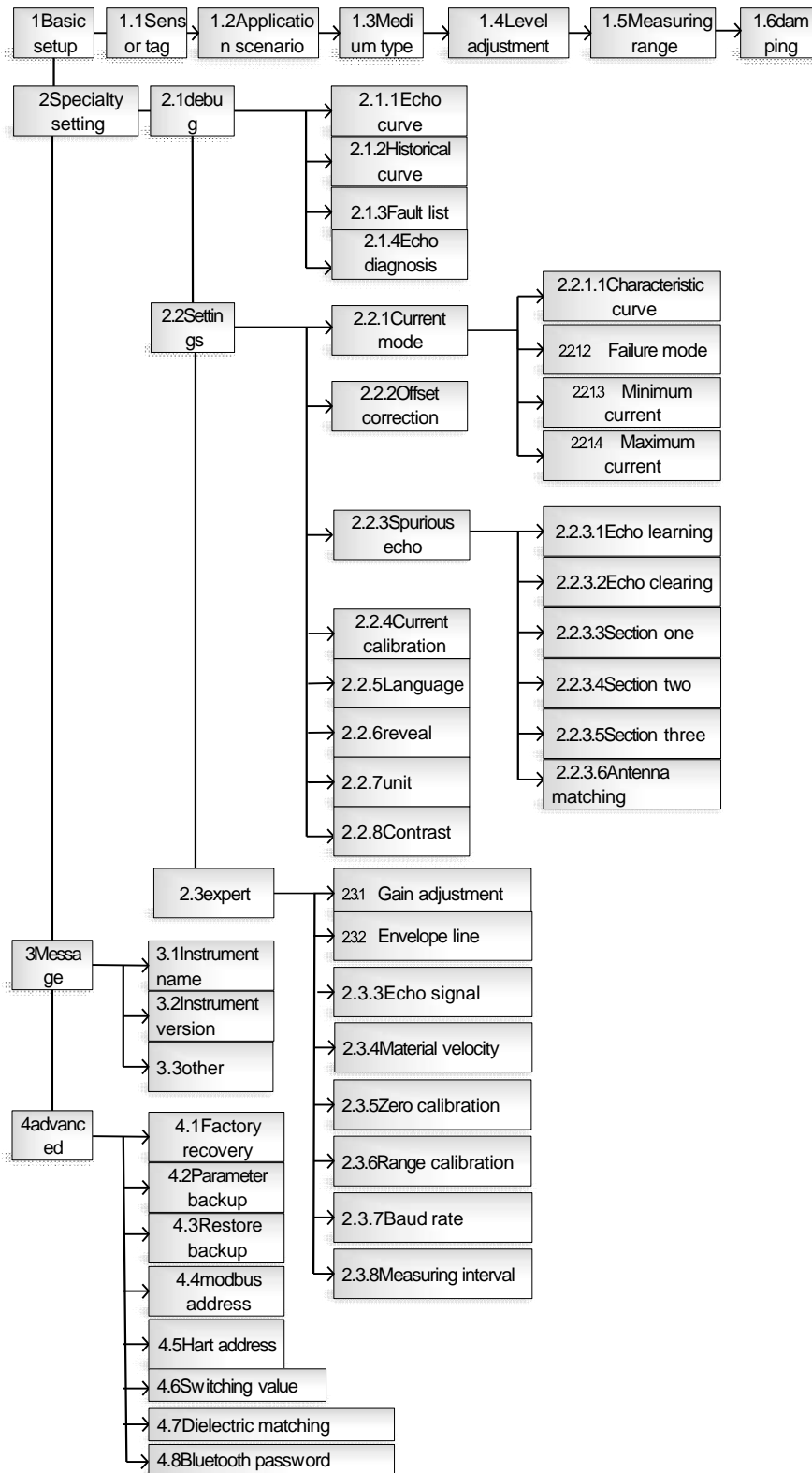


Figure 59 Bluetooth password

- Location: General 4.8 TAB
- Function: Matches the password during the Bluetooth debugging connection
- Use: type [OK] to operate and confirm, type [+] to set the value size, type [▢] to select the edit location



APPENDIX 1 : MENU TREE





APPENDIX 2 : FAULT LIST

CODE	Fault description	Trouble shooting
E01	Internal data error	Check whether the internal connector is loose
E02	The voltage is above 30V or below 10V	Wait for self-recovery or power off to restart
E03	The temperature is higher than 100 ° C	Power off for a moment, then power on again
E04	Internal data transmission fails. Procedure	Wait for self-recovery or factory Settings to be restored
E05	Data upload failure	Wait for self-recovery or factory Settings to be restored
E06	Similar functions are not satisfied	Adjustment parameter
E07	Description Failed to initialize parameter configuration	factory data reset
E08	The measured voltage is less than 12V	Wait for self-recovery or factory Settings to be restored
E09	Boot program self-test failed	Wait for the repeat self-test to pass

APPENDIX 3 : MODBUS

❖ MODBUS PROTOCOL INTRODUCTION

Modbus is an industrial protocol developed in 1979 to enable communication between automated devices. The Modbus serial link protocol operates as a master-slave architecture. At any given time, only one master node connects to the bus, while one or more slave nodes (up to a maximum of 247) connect to the same serial bus. Modbus communication is always initiated by the master node. Slave nodes never transmit data unless explicitly requested by the master. Slave nodes never communicate with each other. The master initiates only one Modbus transaction at a time. Typically, the master device is a Human-Machine Interface (HMI) or a Supervisory Control and Data Acquisition (SCADA) system, while slave devices include sensors, Programmable Logic Controllers (PLCs), or Programmable Automation Controllers (PACs).

At the physical layer, Modbus serial link systems can utilize different physical interfaces (RS485, RS232). The most common is the TIA/EIA-485 (RS485) two-wire interface.

Modbus supports two serial transmission modes: RTU (Remote Terminal Unit) mode and ASCII mode. The primary advantage of RTU mode is its higher transmission density, achieving greater throughput than ASCII mode at the same baud rate. This device utilizes RTU transmission mode.

Note: Unless otherwise specified, data prefixed with 0x in this document represents hexadecimal values (e.g., hexadecimal 0x10 corresponds to decimal 16). All other data is assumed to be decimal values.

❖ RTU MODE FRAME STRUCTURE

MODBUS ADDRESSING RULES

Broadcast Address	Substation Individual Address	Reserved
0	1-247	248-255

Table 1 Modbus Addressing Rules

The address ID of this device can be set within the range: 1-99

Function codes supported by this device

Function Code	Chinese Meaning	English Meaning	Bit/Word Operation	Number of Operations
0x03	Read Hold Register	READ HOLDING REGISTER	Word Operation Note	Single or multiple
0x06	Write a single hold register	WRITE SINGLE REGISTER	Word Operation Notes	Single
0x10	Write Multiple Hold Registers	WRITE MULTIPLE REGISTER	Word Operation Notes	Multiple

Table 2 Device Supported Function Codes

Note: 1 register = 1 word, 1 word = 2 bytes.

❖ DATA FORMAT

Data Read: Function Code = 0x03

In the slave device, read the value of a single or multiple latch registers.

Request Frame:

Slave Address	Function Code	Register Start Address H	Register Start Address L	Register Quantity H	Register Quantity L	CRC Check L	CRC Check H
---------------	---------------	--------------------------	--------------------------	---------------------	---------------------	-------------	-------------



1 byte	1 byte	1 byte	1 byte	1 byte	1 byte	1 byte	1 byte
--------	--------	--------	--------	--------	--------	--------	--------

Table 3 Host Read Request Frame
Response Frame:

Slave Address	Function Code	Data Length	Data Content	CRC Check L	CRC Check H
1 byte	1 byte	1 byte	Note Data Length	1 byte	1 byte

Table 4 Slave Response Frame

Note: Data length = number of registers × 2 (in bytes), 1 register = 2 bytes.

Example: Host requests empty high value from slave address = 0x01; slave responds with empty high = 5.000m

<Column: Request Frame>

Slave Address	Function Code	Register Start Address H	Register Start Address L	Register Quantity H	Register Quantity L	CRC Check L	CRC Check H
0x01	0x03	0x10	0x00	0x00	0x02	0xC0	0xCB

Table 5 Host Request to Read Empty High Value

<Column: Response Frame>

Slave Address	Function Code	Data Length	Data	CRC Check L	CRC Check H
0x01	0x03	0x04	0x40, 0xA0, 0x00, 0x00	0xEF	0xD1

Table 6: Slave Response Empty High Value

◆The read empty high data is represented as floating-point data in IEEE 754 format, with data byte order in big-endian mode.

Single Register Write: Function Code = 0x06

Setting a specified latch register in the slave

Request Frame:

Slave Address	Function code	Register Start Address H	Register Start Address L	Set Value H	Set Value L	CRC Check L	CRC Check H
1 byte	1 byte	1 byte	1 byte	1 byte	1 byte	1 byte	1 byte

Table 7 Host Write to Single Register
Acknowledgment Frame:

Slave Address	Function Code	Register Start Address H	Register Start Address L	Set Value H	Set Value L	CRC Check L	CRC Check H
1 byte	1 byte	1 byte	1 byte	1 byte	1 byte	1 byte	1 byte

Table 8 Slave Response Frame

◆Example: Master requests changing slave address = 0x01 to slave address = 0x02; slave responds with

<Column: Request Frame>

Slave Address	Function Code	Register Start Address H	Register Start Address L	Set Value H	Set Value L	CRC Verify L	CRC Check H
0x01	0x06	0x40	0x06	0x00	0x02	0xFD	0xCA

Table 9 Host-to-Slave Address Request Frame

<Column: Response Frame>

Slave Address	Function Code	Register Start Address H	Register Start Address L	Set Value H	Set Value L	CRC Check L	CRC Check H
---------------	---------------	--------------------------	--------------------------	-------------	-------------	-------------	-------------



0x01	0x06	0x40	0x06	0x00	0x02	0xFD	0xCA
------	------	------	------	------	------	------	------

Table 10 Slave Response Frame

Multiple Register Write: Function Code = 0x10
Write multiple consecutive registers in the slave device
Request Frame:

Slave Address	Function Code	Register Start Address H	Register Start Address L	Register Quantity H	Register Quantity L	Data Bytes Length	Register Data	CRC Check L	CRC Check H
1 byte	1 byte	1 byte	1 byte	1 byte	1 byte	1 byte	Data Length	1 byte	1 byte

Table 11 Host Write Multiple Registers Request Frame

Note: Data length = number of registers × 2 (in bytes), 1 register = 2 bytes.

Response Frame:

Slave Address	Function Code	Register Start Address H	Register Start Address L	Number of Registers H	Number of Registers L	CRC Check L	CRC Check H
1 byte	1 byte	1 byte	1 byte	1 byte	1 byte	1 byte	1 byte

Table 12 Slave Response Frame

◆ Example: The master requests writing floating-point data to four registers starting at register address 0x2000 in slave address 0x01 (corresponding sequentially to: low-order value = 12.5m and high-order value = 0.5m)

<Column: Request Frame>

Slave Address	Function Code	Register Start Address H	Register Start Address L	Register Count H	Register Count L	Data Bytes Length	Register Data	CRC Check L	CRC Check H
0x01	0x10	0x20	0x00	0x00	0x04	0x08	0x41, 0x48, 0x00, 0x00, 0x3F, 0x00, 0x00, 0x00	0xC8	0xF6

Table 13 Host Continuous Write Register

<Column: Acknowledgment Frame>

Slave Address	Function Code	Register Start Address H	Register Start Address L	Number of Registers H	Number of Registers L	CRC Check L	CRC Check H
0x01	0x10	0x20	0x00	0x00	0x04	0xCA	0x0A

Table 14 Slave Response Frame



❖ SERIAL PORT CONFIGURATION

The serial port configuration parameters for MODBUS are shown in Table 5:

Parameter	Setting Value
Baud Rate	9600
Parity Bit	None
Data bits	8
Stop Bit	1

Table 11 Modbus Serial Port Parameter Configuration

❖ REGISTER ADDRESS TABLE

Register Address (Hexadecimal)	Register Address (Decimal)	Register Number	Meaning	Function Code	Byte Order
0x0000	0	2	Clear Height (Unit: m, float)	0x03	ABCD
0x0002	2	2	Material Height (Unit: m, float)	0x03	ABCD
0x0004	4	2	Material Height Percentage (0.0~100.0, float)	0x03	ABCD
0x0006	6	2	Current (Unit: mA, float)	0x03	ABCD
0x0008	8	2	Reserved	0x03	
0x000A	10	2	Reserved	0x03	
0x000C	12	2	Reserved	0x03	
0x000E	14	2	Motherboard Temperature (Unit: ° C, float)	0x03	ABCD
0x0010	16	2	Empty Height (Unit: cm, int)	0x03	ABCD
0x0012	18	2	Clearance Height (Unit: mm, int)	0x03	ABCD
0x0014	20	2	Material Height (Unit: cm, int)	0x03	ABCD
0x0016	22	2	Material Height (Unit: mm, int)	0x03	ABCD
0x1000	4096	2	Low-order adjustment value (Unit: m, float)	0x03,0x10	ABCD
0x1004	4100	2	High-order adjustment value (Unit: m, float)	0x03,0x10	ABCD
0x1008	4104	2	Damping time (Unit: Sec, int)	0x03,0x10	ABCD
0x100A	4106	2	Measurement Range (Unit: m, float)	0x03,0x10	ABCD
0x100C	4108	2	Blind Zone (Unit: m, float)	0x03,0x10	ABCD
0x0100	256	2	Altitude (Unit: m, float)	0x03	CDAB
0x0102	258	2	Material Height (Unit: m, float)	0x03	CDAB
0x0104	260	2	Material Height Percentage (0.0~100.0, float)	0x03	CDAB
0x0106	262	2	Current (Unit: mA, float)	0x03	CDAB
0x0108	264	2	Motherboard Temperature (Unit: ° C, float)	0x03	CDAB
0x010A	266	2	Low-order adjustment value (Unit: m, float)	0x03,0x10	CDAB
0x010C	268	2	High-order adjustment value (Unit: m, float)	0x03, 0x10	CDAB
0x010E	270	2	Measurement Range (Unit: m, float)	0x03,0x10	CDAB
0x0110	272	2	Blind Zone (Unit: m, float)	0x03,0x10	CDAB
0x0112	274	2	Write the 32-bit integer value 111 to this address Device begins restarting	0x10	CDAB



0x0114	276	1	Alarm Type (int16) 1: Single point 2: Dual point	0x03, 0x10	AB
0x0115	277	1	Alarm Level (int16) 0: Low Level 1: High Level	0x03, 0x10	AB
0x0116	278	2	Single-point alarm value (Unit: m, float)	0x03,0x10	CDAB
0x0118	280	1	Single-point alarm range (int16) 0: Upper limit alarm 1: Lower limit alarm	0x03, 0x10	AB
0x0119	281	2	Upper Limit Alarm Value for Double Points (Unit: m, float)	0x03,0x10	CDAB
0x011B	283	2	Lower Limit Alarm Value for Double Points (Unit: m, float)	0x03,0x10	CDAB
0x011D	285	2	Alarm hysteresis value (Unit: m, float)	0x03,0x10	CDAB
0x011F	287	1	Relay 1 Alarm Status (int16): 0: No alarm 1: Alarm	0x03	AB
0x0120	288	1	Relay 2 Alarm Status (int16): 0: No alarm 1: Alarm	0x03	AB
0x3006	12294	1	Slave Address	0x03,0x10	AB

Table 12 Register Address Definitions

Note:

Returns empty high value and material high value in floating-point format (IEEE 754 standard), with byte sequence in big-endian order, units in meters.

Returns empty level or material level as a long integer (4 bytes) in big-endian byte sequence.

Returns empty height and material height values in floating-point format (IEEE 754 standard, modscan32 Flo



MIAL®
INSTRUMENTS PVT.LTD.
Measuring & Beyond

info@mialinstruments.com
+91 9913449547 | +91 9913449548

USA OFFICE : DOWNTOWN REPUBLIC CENTER , 325 N. ST.PAUL STREET, SUITE 3100,DALLAS 75201 ,TEXAS,USA
FACTORY 1 : 856/6 GIDC MAKARPURA, VADODARA, GUJARAT-390010
FACTORY 2 : 0, 195, AATMIYA BROOKFIELDZ INDUSTRIAL PARK, POR, UNTIYA KAJAPUR, VADODARA, GUJARAT- 391243



www.mialinstruments.com