

| INSTALLATION & OPERATION MANUAL

MUF 1000 Portable Ultrasonic Flow Meter



MIAL[®]
INSTRUMENTS PVT.LTD.
Measuring & Beyond

www.mialinstruments.com

MUF 1000

Portable Ultrasonic Flow Meter

Preface

- Thank you for purchasing our product.
- This manual is about the various functions of the product, wiring methods, setting methods, operating methods, troubleshooting methods, etc.
- Please read this manual carefully before operation, use this product correctly to avoid unnecessary losses due to incorrect operation.
- After you finish reading, please keep it in a place where it can be easily accessed at any time for reference during operation.



NOTE!

Modification of this manual's contents will not be notified as a result of some factors, such as function upgrading. We try our best to guarantee that the manual content is accurate, if you find something wrong or incorrect, please contact us. The content of this manual is strictly prohibited from reprinting or copying.

About this manual

- Please submit this manual to the operator for reading.
- Please read the operation manual carefully before installing the instrument. On the precondition of full understanding.
- This manual only describes the functions of the product. The MIAL Instruments pvt.ltd. does not guarantee that the product will be suitable for a particular application.

Warnings and symbols used



HAZARD!

If not taken with appropriate precautions, will result in serious personal injury, product damage or major property damage.



WARNING!

Pay special attention to the important information linked to product or particular part in the operation Manual



CAUTION!

Disregarding these instructions can result in damage to the device or to parts of the operator's plant.



INFORMATION!

These instructions contain important information for the handling of the device.



Table of Content

Preface	1
About this manual	1
1. INTRODUCTION	3
1.1 PURPOSE OF THE MANUAL.....	3
1.2 OPERATING PRINCIPLE.....	4
1.3 TECHNICAL SPECIFICATIONS*.....	5
2. DEVICE DESCRIPTION	6
2.1 SCOPE OF DELIVERY.....	6
2.2 NAMEPLATES.....	6
2.3 DIMENSION MUF 1000 FLOW METER.....	7
3. INSTALLATION	8
3.1 INSTALLATION, STORAGE AND PROMPTS.....	8
3.2 PIPE DESIGN & SELECTION.....	8
3.3 TRANSDUCER INSTALLATION.....	11
4. ELECTRICAL CONNECTIONS	16
4.1 SAFETY INSTRUCTIONS.....	16
4.2 TRANSMITTER CONNECTIONS.....	17
5. OPERATION	19
5.1 POWER ON.....	19
5.2 BOOT SCREEN.....	19
5.4 KEYBOARD OPERATION.....	20
5.5 FUNCTION.....	20
APPENDIX -1 COMMUNICATION INTERFACE AND COMMUNICATION PROTOCOL	40
APPENDIX -1 FLOW VELOCITY CHART	46

1. INTRODUCTION

1.1 PURPOSE OF THE MANUAL

Overview:

Welcome to the user manual for the MUF 1000 Portable Ultrasonic Flow Meter. This comprehensive guide is designed to assist operators, maintenance personnel, and system integrators in understanding, installing, operating, and maintaining the Mial MUF 1000 Portable Ultrasonic Flow Meter effectively.

Objectives:

Clarification of Functionality: This manual aims to provide a clear understanding of the principles and functionality of the Mial MUF 1000 Portable Ultrasonic Flow Meter. Users will gain insights into its design, components, and how it precisely measures fluid flow.

Guidance for Installation:

Step-by-step instructions and considerations for proper installation are provided to ensure optimal performance. Safety precautions are emphasized to create a secure working environment.

Training and Familiarization:

Users will be guided through the features, controls, and indicators of the flow meter, facilitating efficient operation. This section aims to serve as a valuable training resource for users at various experience levels.

Maintenance and Troubleshooting Assistance:

Learn about routine maintenance procedures and effective troubleshooting techniques. This manual empowers users to address common issues and perform regular maintenance to enhance the longevity of the MUF 1000 Portable Ultrasonic Flow Meter

Intended Audience:

This manual is intended for operators, maintenance personnel, and system integrators involved in the installation, operation, and maintenance of the Mial MUF 1000 Portable Ultrasonic Flow Meter. It is suitable for both novice users seeking basic guidance and experienced professionals looking for specific details.

Important Notes:

Please read through the manual carefully, adhering to safety guidelines and following instructions precisely. If any uncertainties arise during the installation, operation, or maintenance processes, seek assistance from qualified personnel or our customer service / support team.

Reference to Other Documentation:

Refer to the accompanying technical specifications document for in-depth details about the MUF 1000 Portable Ultrasonic Flow Meter . Additional resources can be found on our website.

Intended use



CAUTION!



Responsibility for the use of the measuring devices with regard to suitability, intended use and corrosion resistance of the used materials against the measured fluid lies solely with the operator.



INFORMATION!

The manufacturer is not liable for any damage resulting from improper use or use for other than the intended purpose

Certification



The manufacturer certifies successful testing of the product by applying the ISO marking

1.2 OPERATING PRINCIPLE

This series of ultrasonic flowmeter is an industrial time-difference type ultrasonic flowmeter. It applies the latest industrial-level PFGA 700-thousand-gate-array chip, which extremely improves the signal sampling frequency and bubble tolerance rate; the self-developed TGA technology makes it be capable of dealing with more complex logic and calculation to provide more accurate and faster measurements, and ensures the flowmeter could endure non-continuous bubbles or impurities within 5 sec. In addition, it could be installed and operated in a convenient way with no need to break the pipe or cut off the fluid or stop work.

Time-difference type ultrasonic measurement indicates determining the fluid flow along the average velocity with the time difference between two ultrasonic signals transmitting downstream or upstream in the same stroke.

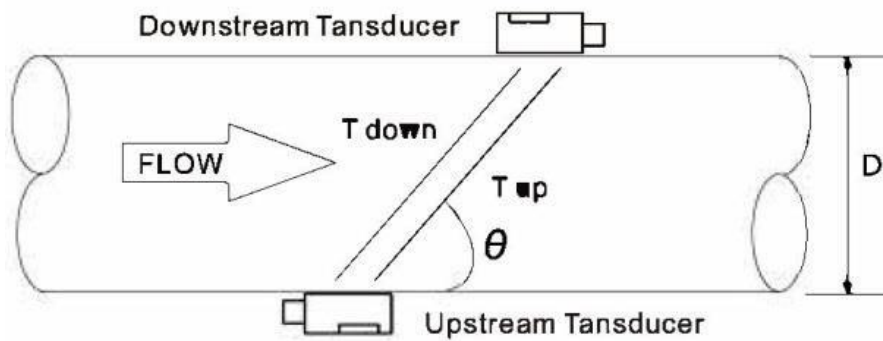

$$V = \frac{MD}{\sin 2\theta} \times \frac{T_{up} - T_{down}}{T_{up} + T_{down}}$$

In which,

- v Fluid velocity
- M Ultrasonic reflections
- D Pipe diameter
- θ Included angle between ultrasound signal and fluid



Tup Time that downstream transducer sends signal to upstream
Tdown Time that upstream transducer sends signal to downstream
 $\Delta T = T_{up} - T_{down}$

1.3 TECHNICAL SPECIFICATIONS*

Flow measurement

Ultrasonic differential transit-time Technology

Fluid types

Water

Flow range

$\pm 0.09 \text{ft/s} \sim \pm 16 \text{ft/s}$ ($\pm 0.03 \text{m/s} \sim \pm 5 \text{m/s}$)

Accuracy

$\pm 1\%$ of measured value

Pipe sizes

1" to 48" (25mm to 1200mm).

Pipe material:

Carbon steel, stainless steel, PVC and other compact material pipe

Function

Outputs

Analog output: 4~20mA, maxload 750Ω.

RS 485 Modbus RTU

SD card

16 GB

Power supply

Rechargeable Lithium Battery,
3000mAh (Continuous operation

of main battery 16 hours).

Display

240*128 back lit LCD

Transducer

-15 Deg C ~ 80 Deg C

Humidity

Up to 99% RH, non-condensing

Physical

Transmitter

NEMA 13, IP54

Transducer

Encapsulated design, IP68 Standard

Transducer cable

Cable length: 5m

Keyboard

Digital keys

*Specifications are subject to change without prior notice

2. DEVICE DESCRIPTION

2.1 SCOPE OF DELIVERY



INFORMATION!

Do a check of the packing list to make sure that you have all the elements given in the order



INFORMATION!

Inspect the packaging carefully for damages or signs of rough handling. Report damage to the carrier and to the local office of the manufacturer.

2.2 NAMEPLATES



INFORMATION!

Look at the device nameplate to ensure that the device is delivered according to your order. Check for the correct supply voltage printed on the nameplate



INFORMATION!

Please check the nameplate and confirm whether the goods are identical with your order or not. Check whether the power supply on the nameplate is correct or not. The following shows information on the nameplate:

NAMEPLATE FOR THE TRANSMITTER (FLOW METER)

Ultrasonic Flowmeter	
Model:	Max. Operating Temperature ℃
Specification	Pressure Rating <u>Mpa</u>
Power Supply VDC	Meter Factor
Accuracy Class	Measuring Range
Output	Product No.



2.3 DIMENSION FOR MUF 1000 FLOW METER

Transmitter size

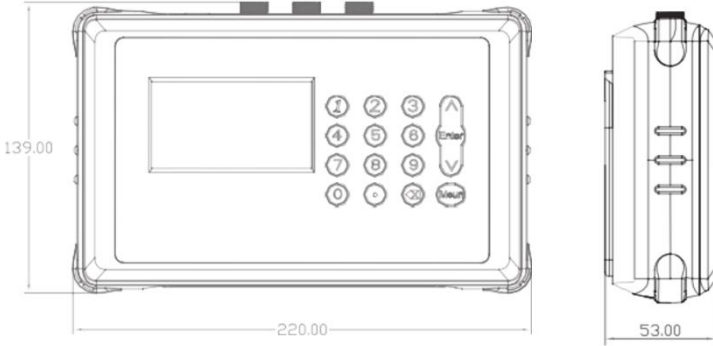

transducer size

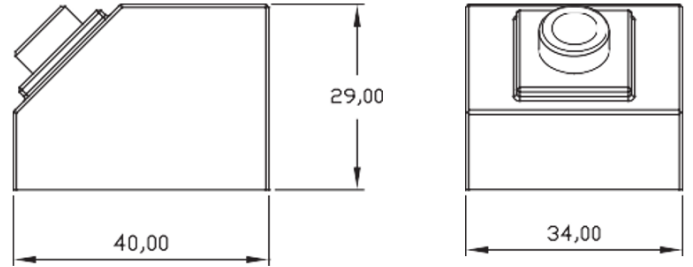

ST mounting kit size

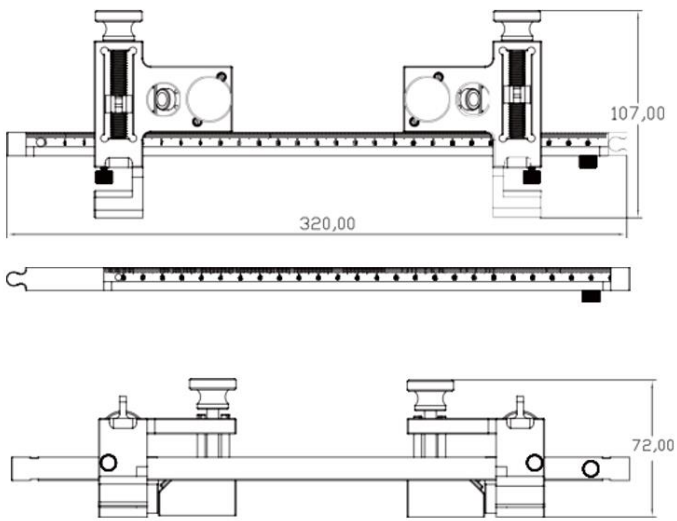

DT mounting kit size

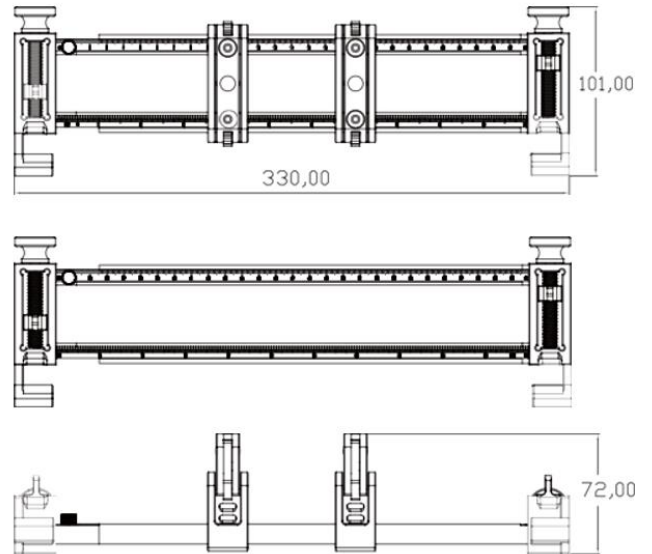

D2 transducer size

D2 mounting bracket size

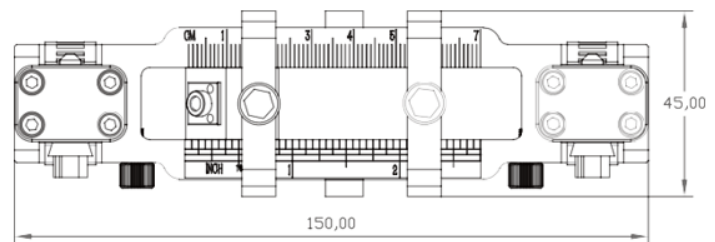
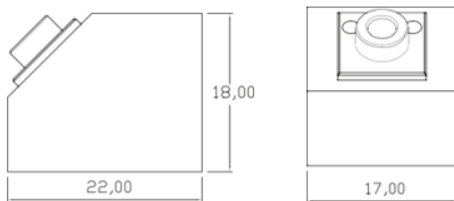

3. INSTALLATION

3.1 INSTALLATION, STORAGE AND PROMPTS



CAUTION!

Please carefully check whether the packing case is damaged or loaded/unloaded in an improper way or not. If it is damaged, please notify the delivery man and the manufacturer or the consignor and describe the damage in details.



CAUTION!

Please check the goods you received with the packing list.



CAUTION!

Please check the nameplate and confirm whether the goods are identical with your order or not. Check whether the power supply on the nameplate is correct or not; if not, please contact the manufacturer or the vendor.



INFORMATION!

*Please store the flowmeter in a dry and dust-free place;
Avoid long-term direct sunlight;
Keep the flowmeter in the original packing case;*



CAUTION!

*To ensure reliable installation, DO take the following measures:
Before installing the flowmeter, DO take into account of the flowmeter's diameter,
pipe size and installation position. Correct installation could ensure accurate output signals, less
maintenance and maximum performance.*

3.2 PIPE DESIGN AND SELECTION

The following should be taken into account when selecting a pipe:

3.2.1 INSTALLATION ENVIRONMENT

- It's better to install the flowmeter indoors; if you have to install it outdoors, you should take measures to avoid direct sunlight or rainwater.
- The flowmeter shall be installed away from high temperature, thermal radiation from equipment or corrosive gas.
- Ultrasonic flowmeters can't be installed nearby motors, transformers or other power sources that are easy to cause electromagnetic interference. DO NOT install ultrasonic flowmeters nearby frequency converters or DO NOT connect it with the distributing cabinet of frequency converters to avoid interference.

- In convenience for installation and maintenance, keep sufficient space around the flowmeter.

3.2.2 SUPPORT OF FLOWMETER

Avoid installing the flowmeter on pipes with mechanical vibrations. If you have to install it there, DO take shock absorption measure. You could install a hose for transition, or set support points with absorbing pads on the pipe at 2DN in both upstream and downstream of the flowmeter. Try not to install the flowmeter on the longer overhead pipes because the sagging of pipes would cause leakage between the flowmeter and the flanges. If you have to do it, you must set support points on the pipe at 2DN in both upstream and downstream of the flowmeter.

3.2.3 REQUIREMENTS ON LIQUID-RECEIVING MATERIAL

The ultrasonic flowmeter could measure single-medium liquid flow; The same medium could be divided into three specifications (low temperature, high temperature and superhigh temperature), different flowmeters should be used for different temperatures.

3.2.4 DANGEROUS CONDITIONS

You could select the flowmeter with an explosion-proof housing, and intrinsic safety explosion-proof flowmeter with intrinsic safety design circuit to ensure its safety and flame-retardant operation. Each flowmeter should have a nameplate clearly identifying its certifications. Please DO install and use the flowmeter according to the explosion-proof grade and protection grade as shown on the nameplate.



CAUTION!

DO ensure that the flowmeter is filled. DO NOT make the liquid flow downwards vertically, or it may have bubbles

3.2.5 REQUIREMENTS ON THE FRONT/REAR STRAIGHT PIPE SECTIONS

DO ensure a straight pipe section at least ten times of the pipe diameter (D) in the upstream of the flowmeter and at least five times of the pipe diameter (D) in the downstream of the flowmeter. The nominal accuracy depends on the pipe diameters in the upstream; according to the interference, insufficient front/rear straight pipe sections may cause about 0.5% deviation.

To ensure measurement accuracy of the flowmeter, try to satisfy the following requirements on the length of straight pipe sections installed nearby the flowmeter:
upstream >20D, downstream >10D.



CAUTION!

Try not to disturb the upstream flow distribution. Ensure no valves, elbows or triplets; try to install the



control devices or throttles in the downstream if any, so as to ensure sufficient pipe flow at the measurement point, details are shown below:

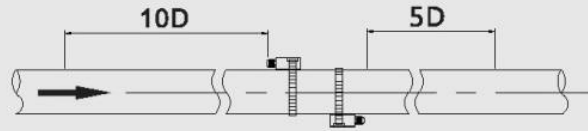

General conditions

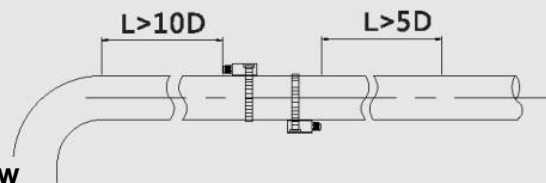

Install after the elbow

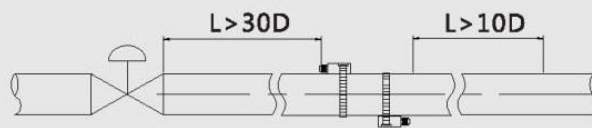

Install after valves

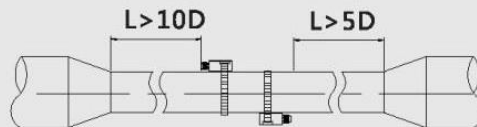

Install on diameter-reduced pipe

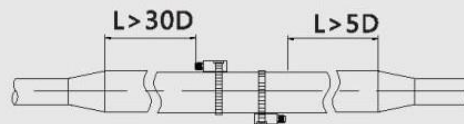

Install on diameter-expanded pipe



3.2.6 REQUIREMENTS ON TRANSDUCER INSTALLATION ANGLE

When being installed on horizontal pipes, the transducer should be installed at 3 o'clock or 9 o'clock, i.e. on both sides of the pipe. It's not recommended to install it on top or at bottom of the pipe because it's easy to cause bubbles at the top and accumulate sands or impurities at the bottom.

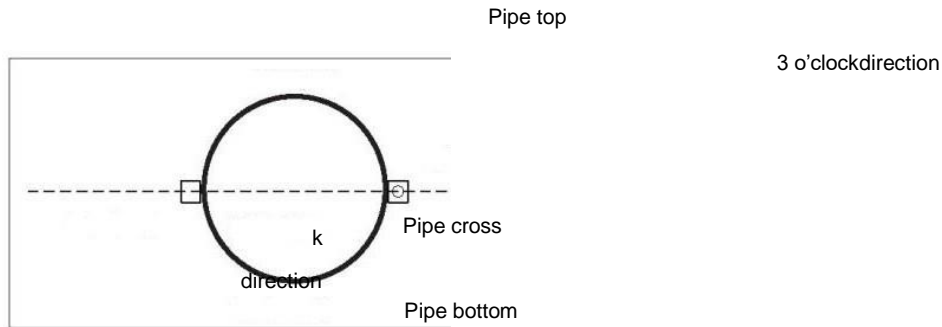

CAUTION!

The measurement point should be in the pipe section with relatively new inner wall with no or relatively less scaling. The pipe must be made of compact material. When selecting the installation point, DO ensure no welding seams or other gaps.

3.3 TRANSDUCER INSTALLATION



CAUTION!

It's better not to unpack it before installing it to designated location to avoid damage. DO NOT heavily throw the flowmeter or press heavily on it, especially the probe surface, or the sealing surface may be damage

3.3.1 TRANSDUCER INSTALLATION MODES

You should choose the way for installation that the client could select a transducer according to the measurement site. Generally, there are two installation methods for transducers: V-shape installation and Z-shape installation.

V-SHAPE INSTALLATION:

Two transducers are installed on one side of the pipe, and the sound wave forms a V-shape reflection path on the pipe wall. This installation method is relatively simple and it is the easiest way. You should keep the two transducers horizontal and make sure the sensing axes are horizontally identical. The signal intensity is relatively weaker than that in Z-shape installation method, so it is widely used for small-diameter installation and better operating conditions.

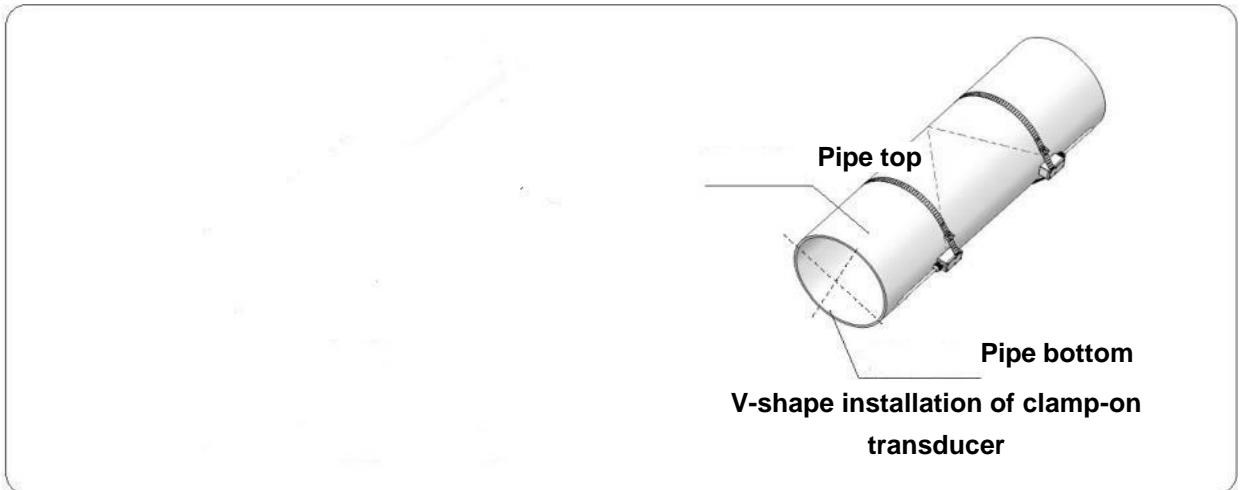

Z-SHAPE INSTALLATION:

Compared with V-shape installation, Z-shape installation is better in signal intensity; sound waves are transmitted directly in the pipe with no reflection (single sound path) and the signal loss is less, so it is recommended to apply Z-shape installation method on the more complicated site and large-diameter pipes.

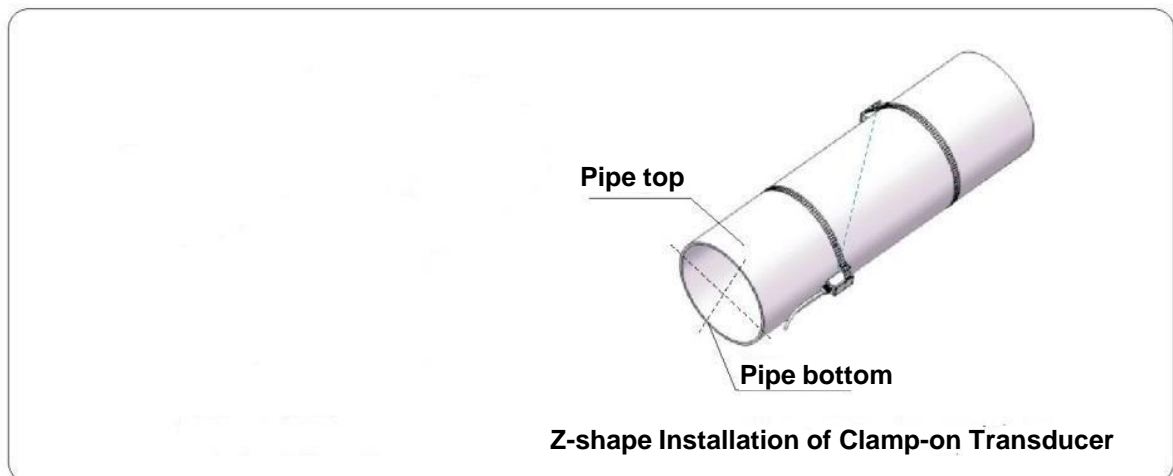

3.3.2 INSTALLATION STEPS OF THE CLAMP-ON TRANSDUCER ARE SHOWN BELOW:

Step 1: Firstly, determine the installation site of the two transducers on the pipe and remove all iron rust, paint stains and dirt.

Step 2: Apply enough couplant on the first half (signal generating position) of the transducers and place it on the pipe, press the transducers against the pipe and ensure there are no voids.

Step3: Lock the steel band clamps and check the installation spacing between the two transducers; slightly adjust the spacing L1 to the value provided in M14 menu of the converter; slightly adjust the



two transducers to one horizontal plane.

Step4: Check whether parameters in M04 menu are within normal scope or not. If not, DO check the following:

- * Check whether related field parameters in the converter are input correctly or not (pipe diameter, wall thickness, material, liner, medium, etc.);
- * Check whether the installation spacing L is identical with the value shown in M14 menu or not;

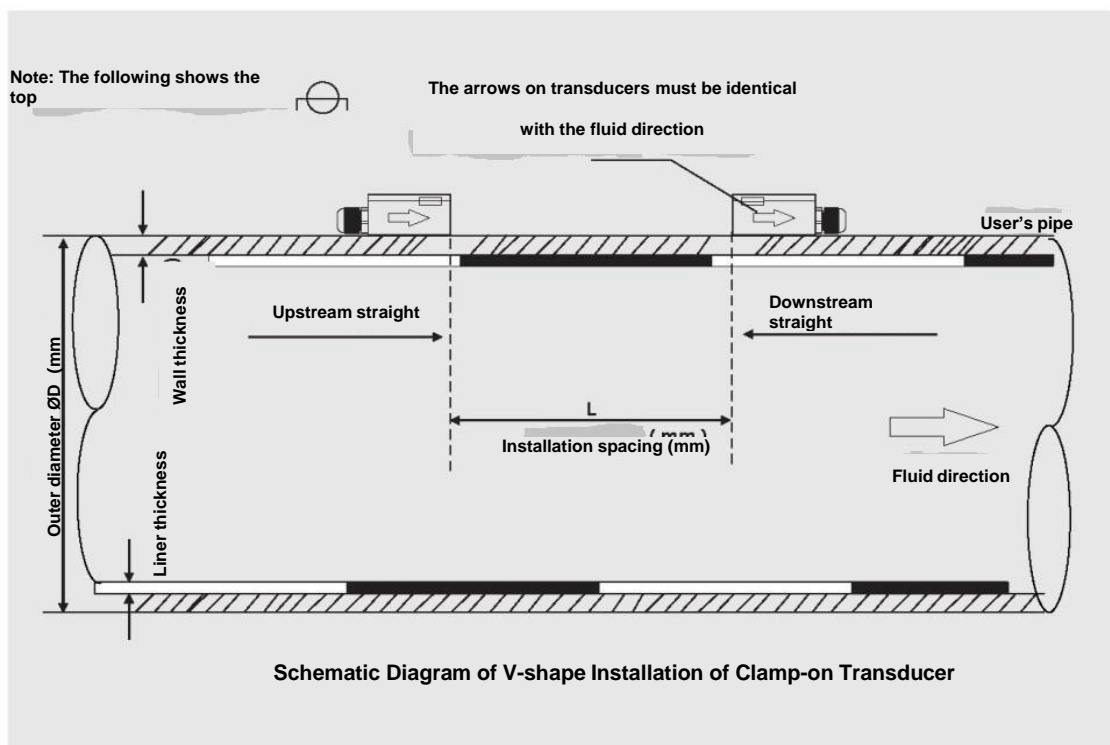
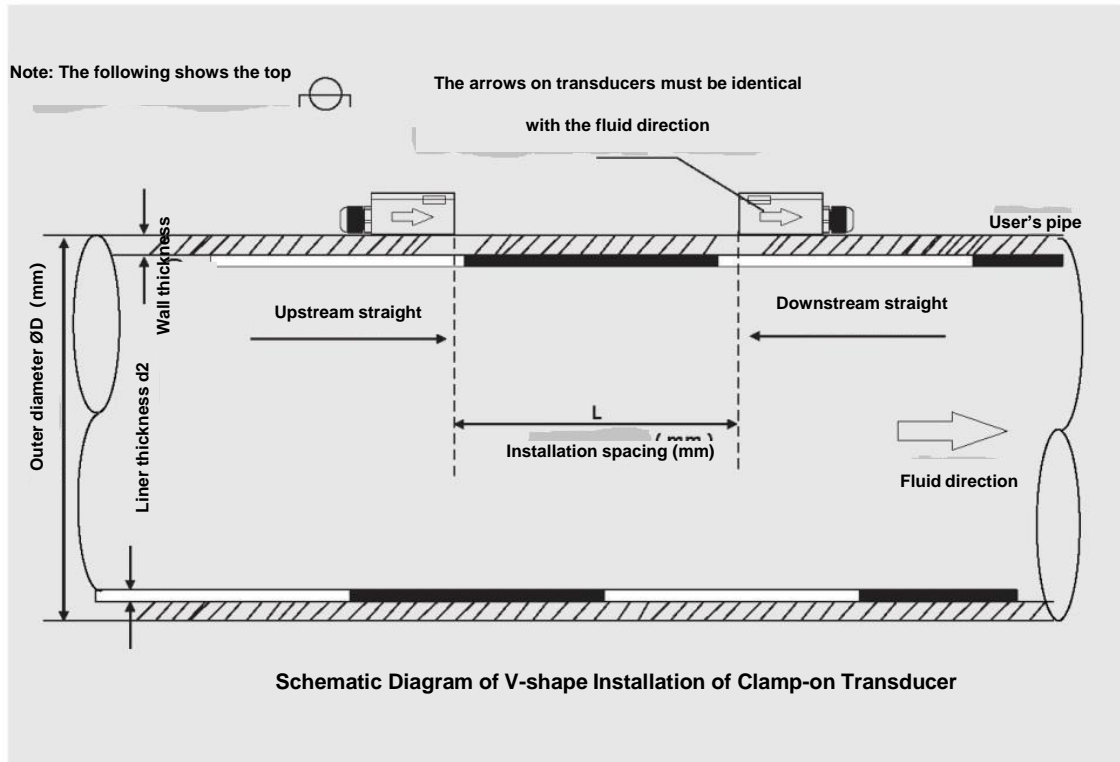

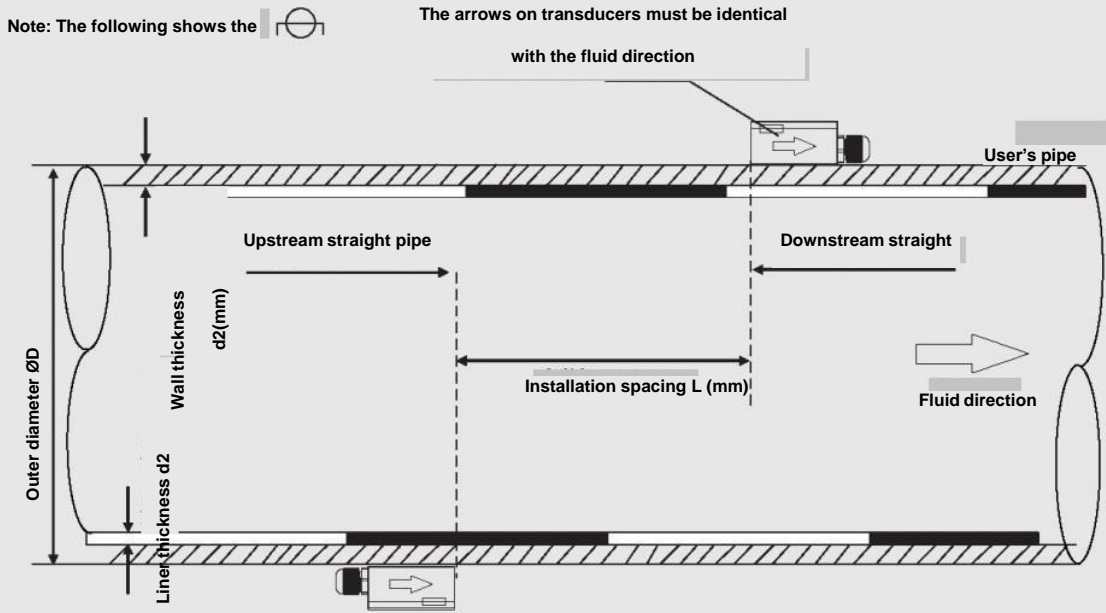

**Schematic Diagram of Z-shape
Installation of Clamp-on Transducer**

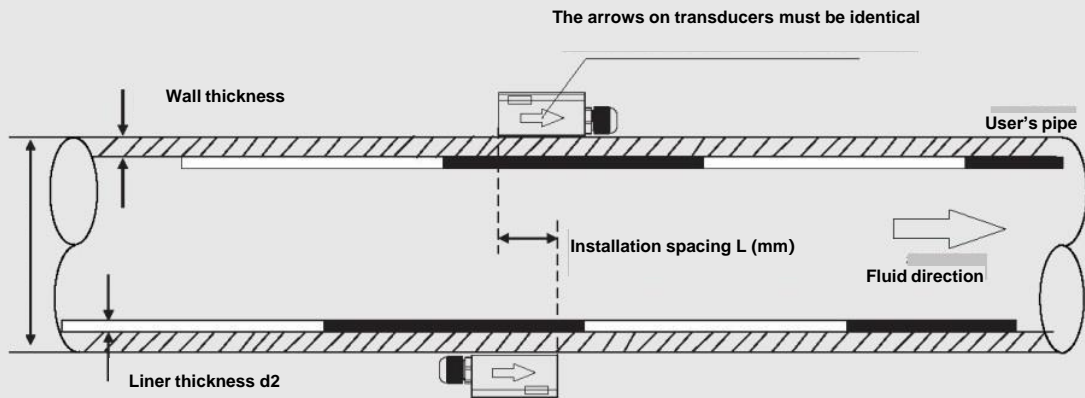

**Schematic Diagram of Z-shape Installation of Clamp-on
Transducer on Pipes with Small Diameter**

3.3 .3 CONFIRMATION ON INSTALLATION QUALITY

On the operation panel, press [Menu]+[4] to enter M04 menu.

M04		Status	*R
Signal	Sound	Time	
UP	DN	Q	
80.0	80.1	85	

SIGNAL INTENSITY (UP/DN INDICATES UPSTREAM/DOWNSTREAM TRANSDUCER):

The ultrasonic flowmeter applies 00.0-99.0 to indicate corresponding signal intensity, the bigger the value, the stronger the signal intensity. In normal operation, the signal intensity of the upstream/downstream transducer should be >75 as required. If the signal intensity is less than 75, please check whether the transducer is correctly installed or not again, check whether the couplant is applied properly or not; check whether the upstream/downstream transducer is on the same horizontal plane or not, and check whether the two transducer's installation spacing is identical with the value shown in M14 or not. If the signal intensity still can't reach up to over 75 in V-shape installation, please choose V-shape installation.

Q value (Signal quality):

Q value (Signal quality) indicates the degree of received signals' quality; the flowmeter applies 00.0-99.0 to indicate relative signal quality, the bigger the value, the better the signal quality. In normal conditions, the signal quality (Q value) should be over 75.

SOUND VELOCITY:

Vel. value indicates the sound velocity and the actual sound velocity measured by the flowmeter. Under normal conditions, it should be close to the sound velocity shown in M12 menu. If the difference is too big, you should check the installation settings and whether it is properly installed or not.

TRANSMISSION TIME (RATIO):

Transmission time is used for checking whether the installation spacing of two transducers is correct or not; If they are installed correctly, the transmission time should be $100\pm 3\%$.

TOTAL TRANSMISSION TIME (UNIT: US) AND TIME DIFFERENCE (UNIT: NS):

When the time difference fluctuates too greatly, the flow and flow rate would change greatly, it indicates that the signal quality is poor, which may be caused by bad pipe conditions, improper installation or parameter errors. Under normal conditions, the fluctuation of time difference should be less than $\pm 20\%$. But when the pipe diameter is too small or the flow rate is extremely low, its fluctuation would exceed the normal value a little.

4 ELECTRICAL CONNECTIONS

4.1 SAFETY INSTRUCTIONS



Warning!

Signal cables and power cables must be connected while the power is off.



Warning!

As specified, the meter must be connected to the protective ground terminal to protect operators from electric shock.



Warning!

As for the meters to be used in hazardous areas, please pay attention to the safety and technical prompts as specified in the professional explosion-proof instructions.



Caution!

Please strictly obey the local occupational health and safety regulations. Only trained personnel are allowed to operate on electrical equipment.



Warning!

Voltage difference is not allowed between the measuring transducer and the housing or protective ground cable of the electronic system.

The measuring transducer must be well grounded according to related standard DESIGN CODE OF INSTRUMENT GROUNDING (HT/T 20513-2014).

The ground conductor shall not transmit any disturbance voltage.

The ground conductor is not allowed to connect other electrical equipment.



4.2 TRANSMITTER CONNECTIONS

4.2.1 POWER SUPPLY



Please pay special attention to the power supply. Please connect related power supply according to the symbols of connecting terminals.

4.2.2 TRANSMITTER CONNECTIONS

Once the flowmeter is installed at the designated place as required, you can start connections.

Open the case, you can see the connecting terminals on the power board from left to right as follows:

Power	Power switch
Output	4-20mA or RS485
UP	
DN	
Charge	

Warning!



Please ensure that the flowmeter is connected with the power off, and ensure that it has been reliably grounded before use.

4.2.3 POWER ON

When switching the power on for the first time, the flowmeter will run automatically according to the parameters you put last time (the meter is calibrated before leaving factory). After the flowmeter is installed and powered on, you can check its status in M04 menu; if it displays “*R”, it indicates that the flowmeter is running normally.

If you use the flowmeter in a new environment, you need to input related parameters. Any parameters you input would be kept in its memories forever till you correct them again. If you need to adjust its installation position or the position of the transducer, you need to input and set related parameters again of the flowmeter to ensure normal use.

DO always finish all tasks when running. No matter in any displays, tasks including measurement and output should be finished as usual.

5 OPERATION

5.1 POWER ON

Warning!



Please check the meter is correctly installed or not before power on, including: Connecting the power supply as specified;
Please check the electrical connection of the supply power is correct or not

5.2 BOOT SCREEN

The flowmeter is composed of the measuring transducer and the signal converter. And the delivery product is ready for putting into use. All operating parameters and settings have been set according to your order requirements.

5.3 (1) Boot screen

In normal display, press [Y] and [A] keys to switch among NET Total, POS Total and NEG Total.

M00	Flow Total		*R
NET	POS	NET	
123.4			E+0 m ³

M00	Flow Total		*R
Net	POS	NET	
123.4			E+0 m ³

Go on pressing [Y] to enter M01 menu to display the flow rate, total flow and transient flow. The following shows how to switch between the flow rate and the total flow.

M01	Flow Rate	*R
0.00		m/s
0.000		m ³ /h

M01	Flow Rate	*R
123.4	E+0	m ³
0.000		m ³ /h



"*R" indicates that the flowmeter is running normally; "D" indicates that the flowmeter is carrying out gain setting; "E" indicates that the flowmeter can't receive any ultrasound signals.



5.4 KEYBOARD OPERATION

5.4.1 description



Use digits [0~9] and [.] to input digits or menu number.

[] key is used for left backspace or deleting the characters on left.

[] and [] keys are used for entering the previous or next menu; the key is plus or minus when inputting digits.

[Menu] key is used for choosing menus. Press the key and then input menu number to enter related menu.

[Enter] key is used for entering the edit mode and confirm the corrections.

5.4.2 Keyboard Operation Methods

The flowmeter menu is divided into six modules according to the functions and field demands. You can directly input the menu number to enter the menu and you also can switch through [] and [] keys.

If you need to correct the flowmeter parameters, please firstly switch to related menu, find out the parameter you want to correct and then press [Enter] to confirm; input the data and then press [Enter] to confirm your corrections.

5.5 FUNCTION



The flowmeter would be calibrated and debugged before leaving factory, and its parameters would be set accurately.

Please carefully read the instructions if necessary.

Non-professionals are not allowed to operate the flowmeter.



5.5.1 COMMON FUNCTIONS

How to Judge its Operating Status

If it displays "*R", it indicates the flowmeter works normally.

If it displays "D", it indicates the flowmeter is carrying out auto gain adjustment before measurement, it is normal most of the time. If it lasts for a long time, it indicates that the flowmeter fails.

If it displays "E", it indicates that the flowmeter can't receive sound wave signals. Please check the connections and installation of transducers. As for more information, please refer to "ERRORS".

Low Flow Cut

M21 menu is the low flow cut menu. The system considers the flow whose absolute value is less than this value as "0", so you can set this parameter to avoid false accumulation of measurement errors of the flowmeter when the actual flow is "0". In general, this parameter is 0.03m/s. When the flow is more than the low flow cut value, the low flow cut value has nothing to do with the measurement result and will have no influences on it.

Zero Point Setting

Any flowmeter has a relative zero point. That is to say, when you judge the flow is zero but the flowmeter doesn't display zero, this value is called zero point. Of course, as for any flow meters, zero point is objective, but its value is controllable. If zero point is not "0", it will cause measurement errors. Moreover, the smaller the measured physical quantity, the greater the error caused by it. Only when zero point is reduced to a certain degree as compared with the measured physical quantity, the error caused by it could be ignored. As for ultrasonic flowmeter, when the flow is smaller, error caused by zero point couldn't be ignored. You need to set zero point to improve the accuracy for small flow measurement. At the time, you need to cut zero point on site.

Cut zero point

M22 menu-Cut-1. Yes, it displays "success" if zero point is cut. and the flowmeter would return to M01 menu.

Reset zero point

M22 menu--Reset-1. Yes

Meter Coefficient

Meter coefficient indicates the specific value of actual flow and the display value of the flowmeter. For example, the actual flow at the measurement point is 3 and the flowmeter displays 2.99, then the meter coefficient is $3/2.99$. Under perfect measurement status, the optimum meter coefficient is "1". However, it's hard to make all flowmeters have the same coefficient in batch production and also because of the changeable environment on site, it's impossible to ensure the meter coefficient of all flowmeters is "1".

Therefore, each flowmeter would be calibrated before leaving factory to get its meter coefficient, which is called K coefficient.

You also could calibrate the flowmeter in service on site through M26 menu.

System Protection

System protection is mainly to avoid abnormal operation of flowmeter in installation or operation because of touching by mistake. When system protection is enabled, you could view the flowmeter but can't correct any parameters.



You could enable or disable this function in M54 menu. You need to enter passcode to activate the function or make alterations.

Current Loop Output

The current loop output accuracy is 0.1%. It is programmable and you can set several output modes like 4~20mA and 0~20mA in M23 menu.

In M32 menu, 4mA/20mA is the minimum/maximum limit value. For example, the flow range in a pipe is 0~1000m³/h, you only need to input 0 and 1,000 respectively in M32 menu. If the flow range is -1,000 ~ 0 ~ 2,000m³/h, and 20 ~ 4 ~ 20mA output is used while not considering the flow direction, you could set 1000 and 2000 as the minimum and maximum limit values respectively in M32 menu.

However, when 0-4-20mA output is used while considering the flow direction, you should consider two different conditions; when the flow direction is reverse, the output current is 0~4mA; when it is forward, the output current is 4~20mA.

“Check” in M32 menu is used for check whether the current loop has been “calibrated” or not. Detailed operation steps:

Use [↑] key to switch among “Check 4mA”, “Check 8mA”, “Check 16mA”, “Check 20mA” readings. At the same time, use the precise ammeter to measure the output current of the current loop, calculate the difference between them and check whether it is in the tolerance or not. You could calibrate 4-20mA in M62 menu.



The integrated pulse should be appropriate; if it is too big, the output period would be too long; If it is too small, the relay would operate too frequently, which would influence its service life; and when it is too fast, it would generate pulse loss. It is recommended to apply 1-3 pulse output/sec.

Alarms

Switch output alarm signal is generated through switching on/off OCTs or relays and output to the external circuit, it is generated under the following conditions:

Transducers can't receive ultrasound signals;

Ultrasound signals that transducers received are too poor;

The flowmeter is not under normal operation;

The flow is reversed;

The analogue output exceeds 100% of the measuring range;

The frequency signal exceeds 120% of the measuring range;

Transient flow exceeds the settings (use software alarm to set the range of flow. There are two software alarms, which are Alarm #1 and Alarm #2T respectively.

How to set? For example 1: It requires the relay outputs alarm signals when the transient flow exceeds 300~1,000m³/h, settings are as follows:

Menu 35, Alarm 1#, lower limit 300;

Menu 35, Alarm 1#, upper limit 1,000;

Menu 34, Relay Settings-Options-Alarm 1#.

4-20mA Output Calibration



The integrated pulse should be appropriate; if it is too big, the output period would be too long; If it is too small, the relay would operate too frequently, which would influence its service life; and when it is too fast, it would generate pulse loss. It is recommended to apply 1-3 pulse output/sec.

Each flowmeter is strictly calibrated before leaving factory. If you are not sure it is calibrated or not, please try not to use this function. If you are sure that the display value is not identical with the actual output current, you could carry out 4-20mA output calibration. Please use M32 menu to check it out first.

Before calibrating the analog input, DO operate the hardware debugging menu as follows:

- a) Please input the passcode to enter Menu 62 to carry out 4-20mA calibration function.
- b) Use [] key to switch and calibrate current loop 4mA output. Use the ammeter to measure the output current of the current loop and adjust the digits displayed at the same time. Observe the ammeter till the reading is 4.00.
- c) Use the same method to calibrate 20mA output.

The calibration data would be automatically saved in EEPROM would not lose when the power is cut.

SD Card Operation Instructions

Note: SD card is optional. Please make sure your flowmeter has such function or not.

Specifications and parameters

Data acquisition frequency could be set from 1 to 99999 sec/time as required.

Data acquired: Time/date, transient flow, flow rate, total flow, POS Total and NEGTotal.

Data storage format:

a = 2017-11-16,16:21:12
 b = + 2.652471E+00 m³/h
 c = +9.380460E-02 m/s
 d = + 3.520580E+02 m³
 e = +3.520580E + 02 m³
 f = +0.000000E+00 m³
 g = +0.000000E+00 GJ/h
 h = +0.000000E+00 GJ
 i = +0.000000E + 00 GJ
 j = + 0.000000E+00°C
 k = +0.000000E+00°Cfile

File system format: FAT16.

File type: Text file (.TXT).

Number of files: 512pcs at maximum.

The file saved each time should be 120 bytes. If the flowmeter saves data once per 5 sec, the file saved in 24 hours is

$120 \times 3600 / 5 \times 24 = 2073600 \text{ byte} \sim 2.1 \text{ Mbyte}$; therefore, 1Gbyte SD card could save data for $1024 / 2.1 = 487.6187$ days. When SD card has not enough storage, new data would automatically cover the earliest files

On-line installation and mobile SD card

DO NOT plug in/out SD card while the power of flowmeter is cut off. DO NOT plug in/out SD card while processing data. You should process file sheets after the data is saved and stored in your computer. If you directly process sheets in SD card files in your computer, and SD card is deleted in processing, you may lose the data or the data may be damaged.

If you want to plug in/out SD card while the power is on, you need to:

Turn the SD switch to "OFF", and then the memory indicator dies out, at this time you could plug in/out the SD card at free will. Plug in SD card in the slot and turn the switch to "ON", and then the memory indicator comes on, SD card could go on saving data.

Product Serial Number

Each flowmeter is provided with a unique product serial number. The serial number is the unique mark for the manufacturer and users for tracing product information and management. You could view your flowmeter's serial number in M 50 menu.



Please refer to "Details about Menus" for operation of other menus.



5.5.2 Description of Operation Menus

Abbreviated codes of menus

Identification	Flow Indication in Level One Menu	Menu Codes and Description
MOX	*R- System running normally *E- Signal unknown *D- Adjusting gain	M00 flow totalizar
		M01 flow rate
		M02 heat
		M03 cool
		M04 measurement status
MIX	Installation settings	M10 pipe section settings
		M11 Liner settigns
		M12 fluid settings
		M13 transducer settings
		M14 installation spacing
M2X	Calibration settings	M20 damping
		M21 low flow cut off
		M22 zero point settings
		M23 totalizar
		M24 temperature
		M25 power cut compensation
		M26 K factor
		M27 correction
		M28 SQA
M3X	Input/output settings	M30 serial port settings
		M32 current settings



Identification	Flow Indication in Level One Menu	Menu Codes and Description
M3X		
		M37 SD card settings (optional)
M4X	Flow unit options in input/output settings	M40 metric unit
		M41 flow unit
		M42 energy unit
		M43 temperature unit
M5X	System settings	M50 serial number
		M51 time and date
		M52 key tone
		M53 languages
		M54 system lock
		M55 system reset
M6X	Others	M60 date totalizar
		M61 running time
		M62 current calibration
		M63 RTD calibration



5.5.3 Menu Configuration

M00

Total Flow

Display flow NET

TotalDisplay flow

POS TotalDisplay

flow NEG Total

Press up/down key to switch

M00	Flow Total	*R
NET	POS	NEG
123.4		E+0 m ³

M01

Flow

Display transient flow and transient velocity NET Total and flow velocity - auto switching and display (6s)

Press ENTER to stop switching and continuously update

Display the current items; Press ENTER again to restore switching.

M01	Flow Rate	*R
0.00		m/s
0.000		m ³ /h

M01	Flow Rate	*R
123.4	E+0	m/s
0.000		m ³ /h



M04

Measurement Status

Display upstream/downstream signal intensity and quality. Signal intensity is expressed by digits from 00.0 to 99.9. 00.0 indicates no signals are received; 99.9 indicates the maximum signal intensity. Generally, the bigger the digit, the stronger the signal intensity; the stronger the signal intensity, the stabler the measurement theoretically. Signal intensity of upstream/downstream transducer should be >75 to ensure normal operation of the flowmeter.

M04		Status	*R
Signal	Sound	Time	
UP	DN	Q	
80.0	80.1	85	

Display the sound velocity and display the actual sound velocity measured by the flowmeter. Under normal conditions, it should be close to the sound velocity shown in M12 menu. If the difference is too big, you should check the installation settings and whether it is properly installed or not.

M04		Status	*R
Signal	Sound	Time	
Vel.	1482	m/s	
Ratio	100%		



Transmission Time

Display the average transmission time of ultrasound measured (Unit: us) and upstream/downstream transmission time difference (Unit: ns). The two readings are the main basis for the flowmeter to calculate the flow velocity, especially the transmission time difference could tell whether the flowmeter is running stably or not the most. Under normal conditions, the fluctuation ratio of the transmission time difference should be less than 20%, if it exceeds 20%, it indicates that the system runs unstably, so you should check whether the transducers are installed in proper position or not and whether parameter settings are correct or not.

M04		Status	*R
Signal	Sound	Time	
Total	185.0	us	
Delta	30.5	ns	

M10

Pipe Section

SettingsPipe

Diameter

Enter the outer diameter and wall thickness. Note: Pipe diameter of this type is from 25mm to 1,200mm.

Select the pipe material in the menu as follows:

0.PVC 1.CS Carbon

Steel 2.SSP (Stainless

M10		Pipe Setting	*R
Size	M.		
OD	108.0	mm	
thk	4.0	mm	

M10		Pipe Setting	*R
Size	M.		
Options	0.PVC		
Others	3200	m/s	



Steel Pipe) 3.CIP

(Cast Iron Pipe)

4. DIP (Ductile Iron Pipe)
5. Copper (Copper Pipe)
6. Alu (Aluminum Pipe)
7. ACP (Asbestos Cement Pipe)
8. FPG (Fiberglass Pipe)
9. Others if you choose Item 9, please input the material velocity

M12 Fluid Settings

Select measure medium, the following options are available:

0. Water
1. Water 125 degC
2. Seawater
3. Kerosene
4. Gasoline
5. Fuel Oil
6. Crude Oil
7. Diesel Oi
8. Castor Oil
9. Peanut Oil
10. Alcohol
11. Propane (-45°C)
12. Butane (0°C)
13. Gas #93
14. Other if you choose Item 14, please input the material velocity.

M12	Pipe Setting	*R
Type	VI S	
Options	0.Water	
Others	1482.0	m/s

Note: Room temperature is 20 °C by default.



M13 Transducer Settings

Select the transducer type:

The following transducer types are available in the menu:

- 0. Clamped D1
- 2. Clamped D1U

M13 Transducer *R		
Type	Method	Mode
Options	0.Clamp D1	

Select the transducer installation methods, the following methods are available:

- 0.V
- 1.Z
- 2.N

Modes

Mode menu is defined by the manufacturer. Please don't make any alterations.

M13 Transducer *R		
Size	Method	Mode
Options	0.V	

M13 Transducer *R		
Size	Method	Mode
Options	0.Mode o	
Other	0.000	

M14 Installation Spacing

Apply the installation spacing of transducers calculated by the flowmeter according to pipe parameters you set.

M14 INST Space *R		
Value		
63.2	mm	



M20 Damping

Damping coefficient is 0~999 sec.

0: Indicates no damping; 999: Indicates the maximum damping.

Damping is used for smoothing the displayed data. In general, you need to enter one digit among 3~10.

M20 Damping		*R
Value	6	

M21 Low Vel. Cut off

Low Flow Cut off is used to make the system display as "0" value at lower and smaller flows to avoid any invalid totalizing. For example, if the cutoff value is set as 0.03, system will take all the measured flow velocity values from - 0.03 to + 0.03 as "0". Generally, 0.03 is recommended in most applications.

M21 Low Vel. Cut off		*R
Value	0.03	m/s

M22 Zero Point Settings

When the fluid is relatively static, we take the display value of the flowmeter as zero. When the "Zero Point" is not zero, the value would be added to the actually measured value, which would cause deviation, so we need to carry out zero point settings.

Static zero point settings must be carried out after the transducers are installed and the

M22 Zero Settings		*R
Cut	Reset	Offset
Options	0. NO	

M22	Zero Settings	
Cut		Reset
Options	0. NO	



fluid inside the pipe is completely static. Through static zero point settings, “zero point” caused by pipe installation position and different parameters could be eliminated, and the low flow measurement accuracy could be improved.

Select “Yes” to reset zero point. Set the zero point value before clearing. After clearing the original zero point value, you could set static zero point according to the measurement environment on the site.

M22		Zero Settings	*R
Cut	Reset	Offset	
Value	0.0	m³/h	

Set zero point deviation

Enter a deviation added on the measured value to get the actual measured value.

It is not recommended for clients to use by themselves or take it as the standard calibration method.

M23 Totalizer

Select the flow accumulation type:

- 0. Positive Totalizer POS Total
- 1. Negative Totalizer NEG Total
- 2. Net Totalizer NET

TotalSelect energy type

- 0. Heat
- 1. Cool

M23		Totalizar	*R
Switch	Reset		
Flow	0.POS	0.ON	
Energy	0.Heat	0.OFF	



Select the flow totalizer you need to reset :

- 0. POS Total
- 1. NEG Total
- 2. NET Total
- 0. Clear all

M23 Totalizar		*R
Switch	Reset	
Flow	0.POS	
Energy	0.Heat	

Select the energy totalizer you need to reset :

- 0. Heat
- 1. Cold
- 2. All

M24 Specific Heat Capacity Settings:

- 0. CJ128SHC (National Standard)
- 1. Others

M24 Temperature		*R
Source	Sensitivity	SHC
Options	0.CJ128	
Others	4.2	KJ/m ³ °C

M25 Power Cut Compensation

Power cut compensation is a function to calculate the current value during the outage based on the average flow before power cut, so as to compensate the total flow.

You could choose to enable/disable the function.

M25 PowerDown COMP		*R
Options	0.ON	

M26 K Factor

Each flowmeter would be calibrated before leaving factory to get its meter

M26 K Fctor		*R
Value	1.00	



coefficient, which we call the K coefficient.

You also could calibrate the flowmeter in service on site through M26 menu.

**M27
Correction**

Linear calibration function.

You could choose to enable/disable the function.

This function is enabled by fault in factory settings.

Delay Calibration

This is a technician menu. Please apply the factory settings and DO NOT alter parameters in the menu.

M27	Correction	*R
KArray	Delay	TPC
Options	0.ON	
Value	*****	

M27	Correction	*R
KArray	Delay	TPC
Value	0.0	us

Signal Power Control

This is a technician menu. Please apply the factory settings and DO NOT alter parameters in the menu.

M27	Correction	*R
KArray	Delay	TPC
Options	0.Auto	

**M28
Statistic Analysis**

This is a technician menu. Please apply

M28	SQA	*R
Set	Reset	
Options	0.On	
Value	0.000	



the factory settings and DO NOT alter parameters in the menu.

M28		SQA	*R
Set	Reset		
Options	0.Auto		
Value	0.000		

M30

Serial Port Settings RS485

- 0.2400 None
- 1.4800 None
- 2.9600 None
- 3.19200 None
- 4.38400 None
- 5.56000 None

M30		RS485	*R
Set	Order		
Options	0.2400	None	
Ad	55		

M30		RS485	*R
Set	Order		
Options	a.1-0	: 3-2	

M31

AI Settings

AI1 The upper/lower limit input. AI2 The upper/lower limit input.

M31		AI Setting	*R
AI1	AI2		
LowerL	1.0		
UpperL	1000.0		

M31		AI Setting	*R
AI1	AI2		
LowerL	1.0		
UpperL	1000.0		



M37
SD Card Settings Options

- a. Flow data
 - b. All SD card data acquisition interval could be set.
- Time unit is sec and the storage cycle could be set between 1- 99999 s.

M37	Micro SD	*R
Options	a. Flow data	
Cycle	60s	

M40
Unit System

- The following options are available:
- a. Metric b. British

M40	Toggle Unit	*R
Options	a. Metric	

M41
Flow Unit

- The following options are available: 0.m³ (Cubic Meters)
- 1.I (Liters)
 - 2.GAL (USA Gallons)
 - 3.Imp gal (Imperial Gallons)
 - 4.mg (Million Gallons)
 - 5.cf (Cubic Feet)
 6. US bbl (USA Barrels)
 7. Imp bbl (Imperial Barrels)
 8. Oil bbl (Oil Barrels)

- The following options are available:
/Day/Hour/Min/Se
c Factory setting is
m³/h.

M41	Flow Unit	*R
Unit	MULT.	
Rate	m³/h	
Total	m³	



Flow Accumulation

- Multiple Factor a.x 0.001 (E-3)
- b.x0.01(E-2)
- c.x0.1(E-1)
- d.x1(E+0)
- e.x 10(E+1)
- f.x100(E+2)
- g.x1000(E+3)
- h.x 10000(E+4)

M41		Flow Unit	*R
Unit	MULT.		
Options	d. *1		

a. x 0.001 (E-3)	b. x 0.01(E-2)
c.x 0.1(E-1)	d. x 1(E+0)
e. x 10(E+1)	f. x 100(E+2)
g. x 1000(E+3)	h. x 10000(E+4)

**M50
Serial Number**

Serial number is the only factory code of the flowmeter, and is the unique mark for the manufacturer and the user to trace the product information and its management.

SVN indicates the software version number.

M50		Serial Number	*R
S/N	FT12345		
	6		
SVN	V1.12		

**M51
Time and Date**

You could alter time and date in this menu.

M51		Time and Date	*R
Time	13:10:34		
Date	20200101		



M52
Key Tone

You could choose to turn “on/off” the keytone.

M52		Key Ton	*R
Options	0.ON		

M53
Languages

You could choose the language for the operation interface in this menu:
0. English

M53		Languag e	*R
Options	0.English		

M54
System lock

You could set operation authority. When the system locks, you could only view the menu but cannot alter any parameters. You could unlock the system by entering correct passcode. The passcode is composed of six digits; If you lose or forget it, please contact the manufacturer.

M54		System Lock	*R
Options	0.NO		
Passcode	*****		

M55
System Reset

You could reset the flowmeter to the factory defaults in this menu.

M55		System Reset	*R
Options	0.NO		
Menu	00		



M60

Data totalizer

You could view: Daily Total, Monthly Total and Yearly Total.

In this menu, you could view historical data for a day in the past 31 days, or a month in the past 12 months or a year in the past six years.

M60 Data totalizar *R		
Day	Month	Year
Value	9/10	E+0
Menu	129	m ³

M61

Running Time

You could view the total run time of the flowmeter.

M61 Running Time *R		
Value	500	h

M62

CL adjustment

This menu is for current calibration. 4-20mA calibration.

Note: The flowmeter would be calibrated before leaving factory, so it is not recommended for the user to calibrate it.

M62 CL Adjust *R		
4mA	Enter to go	
20mA	Enter to go	

APPENDIX -1 Communication Interface and Communication Protocol

The flowmeter is provided with an UART protocol, and you also could operate by using RS-485 Modbus. There are two basic structures you could choose for networking, i.e. only applying the analog current output method or directly applying the UART communication method of the flowmeter. The former one is applicable for replacing the old meter in the old monitoring network, while the latter is used for the new monitoring network, which has a lot of advantages like low hardware investment, reliable system operation and etc.

When directly using the UART communication for the monitoring network system, you could use the address identification code as the network address code and use the command extending set with [W] as the communication protocol.

UART Definition

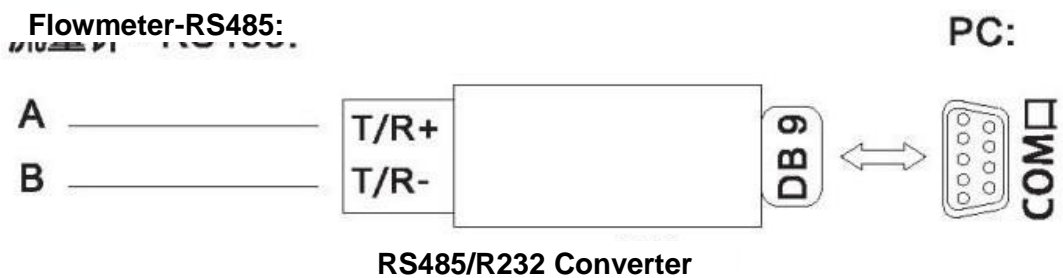

❖ COMMUNICATION PROTOCOL AND ITS USE

The flowmeter supports MODBUS protocol.

MODBUS-I Communication Protocol

MODBUS-I protocol applies RTU transmission mode, and its check code applies CRC-16-IBM (multinomial is $X^{16}+X^{15}+X^2 + 1$, mask code is 0xA001), which is gained through the cyclic redundancy algorithm.

MODBUS-I RTU mode applies the hexadecimal system to transmit data.

MODBUS-I protocol function code and format

Function code	Function data indicated
0x03	Read register
0x06	Single write register



1. Use of MODBUS protocol function code 0x03

Information frame format of the read register sent by the host:

Slave address	Operation function code	Register's first address	Number of registers	Check code
1 byte	1 byte	2 bytes	2 bytes	2 bytes
0x01~ 0xF7	0x03	0x0000 ~ 0xFFFF	X0000 ~ 0x7D	CRC Check code

2. Slave feedback data frame format:

Slave address	Read operation function code	Number of data bytes	Data	Check code
1 byte	1 byte	1 byte	N*x2 bytes	2 bytes
0x01~ 0xF7	0x03	2xN*	N*x2 data	CRC Check code

N* =Number of data registers.

3. MODBUS protocol function code 0x06

4. Information frame format of the write-in single register sent by the host (function code 0x06):

Slave address	Operation function code	Register's first address	Number of registers	Check code
1 byte	1 byte	2 bytes	2 bytes	2 bytes
0x01~0xF7	0x06	0x0000~0xFFFF	X0000 ~ 0xFFFF	CRC Check code

5. Slave feedback data frame format (function code 0x06):

Slave address	Operation function code	Register's first address	Number of registers	Check code
1 byte	1 byte	2 bytes	2 bytes	2 bytes
0x01~0xF7	0x06	0x0000~0xFFFF	X0000~0xFFFF	CRC Check code

Flowmeter's address

Value range is 1~247 (hexadecimal system: 0x01~0xF7), the address could be viewed in Menu 30; if the decimal digit displayed in Menu 30 is 11, the flowmeter's address in MODBUS protocol is: 0x0 B.

The flowmeter's CRC check code is calculated through CRC-16-IBM (multinomial is $X^{16}+X^{15}+X^2 + 1$, mask word is 0xA001) cyclic redundancy algorithms, low byte of the check code is in front, followed by the high byte.

For example, transient flow per hour (m³/h) of the flowmeter with 1 (0x01) read address in RTU mode, i.e. data of two read registers 40005 and 40006, the read commands are shown below: 0x01 0x03 0x00 0x04 0x00 0x02 0x85 0xCA

Flowmeter's address function code/First address register/Number of registers/CRC check code Flowmeter's feedback data (Assuming the current flow=1.234567m³/h):

0x01 0x03 0x04 0x06 0x51 0x3F 0x9E 0x3B 0x32

Flowmeter's address function code/Number of data bytes/Data/CRC check code

In which, four bytes 3F, 9E, 06 and 51 is 1.2345678, which is the single precision float form in IEEE754 format.

Please pay attention to the order of data in the above example. When explaining the value with C language, you could use the pointer to directly input the data required to related address of variable, the common storage order in general is that the low byte is in front. Taking the above 1.2345678m/s example, the storage order of 3F, 9E, 06 and 51 data is 51, 06, 9E and 3F. For example, in RTU mode, alter the address of flowmeter 1 (0x01) to 2 (0x02), i.e. write the data of 44100 register in 0x02,

Write-in commands are shown below:

0x01 0x06 0x10 0x03 0x00 0x02 0xFC 0xCB

Flowmeter's address function code/Register address/Number of registers/ CRC check code Flowmeter's feedback data:

0x01 0x06 0x10 0x03 0x00 0x02 0xFC 0xCB

Flowmeter's address function code/Register address/Number of registers/CRC check code

6. Error processing

The flowmeter only returns the error code 0x02, it indicates that the first address of data is wrong.

For example, when it only reads 40002 register data with address 1 (0x01) in RTU mode, the meter would consider that the data integrity is destroyed, so it sends the following commands: 0x01 0x03 0x00 0x01 0x00 0x01 0xD5 0xCA

Flowmeter's address function code/Register address/Number of registers/CRC check code The flowmeter returns the following error code:

0x01 0x83 0x02 0xC0 0xF1

Flowmeter's address/Error code/Error extension code/CRC check code

7. Address list of MODBUS register

The flowmeter's MODBUS register only includes read-only register and single write-in register.



Address list of read-only register (use 0x03 function code to read)

PDU Adress	Address	Data Reading	Data Writing	Number of Registers	Note
\$0000	40001	Transient flow / sec.-Low byte	32 bits real	2	
\$0001	40002	Transient flow /sec.-Low byte			
\$0002	40003	Transient flow / min.-Low byte	32 bits real	2	
\$0003	40004	Transient flow /min.-Low byte			
\$0004	40005	Transient flow /hour-Low byte	32 bits real	2	
\$0005	40006	Transient flow /hour-Low byte			
\$0006	40007	Flow rate -Low byte	32 bits real	2	
\$0007	40008	Flow rate-Low byte		2	
\$0008	40009	Forward cumulant -Low byte	32 bits int.		
\$0009	40010	Forward cumulant -Low byte			
\$000A	40011	Forward cumulant -Index	16 bits int.	1	
\$000B	40012	Reverse cumulant -Low byte	32 bits int.	2	
\$000C	40013	Reverse cumulant – High byte			
\$000D	40014	Reverse cumulant - Index	16 bits int.	1	
\$000E	40015	NET Total-Low byte	32 bits int.	2	
\$000F	40016	NET Total -Low byte			
\$0010	40017	NET Total -Index	16 bits int.	2	
\$0011	40018	Transient energy -Low byte	32 bits int.	2	
\$0012	40019	Transient energy -Low byte			
\$0013	40020	Energy cumulant (heat)-Low ybyte	32 bits real	2	
\$0014	40021	Energy cumulant (heat)-Low ybyte			
\$0015	40022	Energy cumulant (heat)-Index	16 bits int.	1	
\$0016	40023	Energy cumulant (cold)-Low ybyte	32 bits real	2	
\$0017	40024	Energy cumulant (cold)-Low ybyte			
\$0018	40025	Energy cumulant (cold)- Index	16 bits int.	1	
\$0019	40026	Upstream signal strength-Low byte	32 bits real	2	0-99.9
\$001A	40027	Upstream signal strength-Low byte			



\$001B	40028	Downstream strength-Low byte	signal	32 bits real	2	0-99.9
\$001C	40029	Downstream strength-Low byte	signal			
\$001D	40030	Signal quality		16 bits int.	1	0~99
\$001E	40031	Error code- Character1		String	1	See "Fault analysis"
\$003B	40060	Flow velocityCharacter1,2	unit -	String	2	Only supporting: m/s
\$003C	40061	Flow velocityCharacter3,4	unit -			
\$003D	40062	Transient unit-Character1,2	flow	String	2	Note 1
\$003E	40063	Transient unit-Character3,4	flow			
\$003F	40064	Cumulative unit-Character1,2	flow	String	1	
\$0040	40065	Transient unit-Character1,2	energy	String	2	Note 2
\$0041	40066	Transient unit-Character 3,4	energy			
\$0042	40067	Cumulative -Character 1,2	energy unit	String	1	
\$0043	40068	Instr. Address -Low byte		32 bits real	2	
\$0044	40069	Instr. Address -Low byte				
\$0045	40070	Product serial No.-Character 1,2		String	2	
\$0046	40071	Product serial No.- Character 3,4				
\$0047	40072	Product serial No.-Character 5,6		String	2	
\$0048	40073	Product serial No.-Character 7,8				
\$0049	40074	Analogue input AI1 value-Low byte		32 bits real	2	Returning temperature value when it has RTD
\$004a	40075	Analogue input AI1 value-Low byte				
\$004b	40076	Analogue input AI2 value -Low byte		32 bits real	2	
\$004c	40077	Analogue input AI2 value -Low byte				
\$004d	40078	4~20mA output value-Low byte				



\$004e	40079	4~20mA output value -Low byte	32 bits real	2	Unit: mA
--------	-------	-------------------------------	--------------	---	----------

a) Address list of single write register (Writing with 0x06 function codes)

PDU add.	Register	Data	Read/Write	Data Type	No. of Registers
\$1003	44100	Flowemeter add. (1-255)	R/W	16 bits	int. 1
\$1004	44101	Baud rate 0 = 2400, 1 = 4800, 2 = 9600, 3 = 19200, 4 = 38400, 5 = 56000	R/W	16 bits	int. 1

1. Acceptable flow units: 0."m3"- Cubic Meter

1. "l" - Litre 2."ga"-Gallon 3."ig"- UK Gallon

4."mg"- Trillion Gallon

5."cf"- Cubit Feet

6. "ba"- US

Barrel 7."ib"- UK Barrel 8."ob"- Oil Barrel

2. Acceptable unit cold (heat) units: 0."GJ"-Joule

1."Kc"- Kilocalorie 2."MB"- Btu

"KJ"-Kilojoule

"Bt" - Btu

"Ts"-Metric ton

."Tn"-US ton

7."kw" – Kilowatt hours

16 bits int-indicates short integer, 32 bits int-indicates long integer,

32 bits real-indicates floating point number, String-indicates character s



APPENDIX 1: FLOW RANGE CHART

Unit:m³/h

Size	Flow Range & Velocity Table							
(mm)	0.1m/s	0.2m/s	0.5m/s	1m/s	4m/s	10m/s	12m/s	15m/s
3	0.003	0.005	0.013	0.025	0.102	0.254	0.305	0.382
6	0.01	0.020	0.051	0.102	0.407	1.017	1.221	1.526
10	0.028	0.057	0.141	0.283	1.130	2.826	3.391	4.239
15	0.064	0.127	0.318	0.636	2.543	6.359	7.630	9.538
20	0.113	0.226	0.565	1.130	4.522	11.304	13.56	16.956
25	0.177	0.353	0.883	1.766	7.065	17.663	21.2	26.494
32	0.289	0.579	1.447	2.894	11.575	28.938	34.73	43.407
40	0.452	0.904	2.261	4.522	18.086	45.216	54.26	67.824
50	0.707	1.413	3.533	7.065	28.260	70.650	84.78	105.98
65	1.19	2.39	5.97	11.94	47.76	119.40	143.3	179.10
80	1.81	3.62	9.04	18.09	72.35	180.86	217.0	271.30
100	2.83	5.65	14.13	28.26	113.04	282.60	339.1	423.90
125	4.42	8.83	22.08	44.16	176.63	441.56	529.9	662.34
150	6.36	12.72	31.79	63.59	254.34	635.85	763.0	953.78
200	11.3	22.61	56.52	113.04	452.16	1130.40	1356	1696
250	17.66	35.33	88.31	176.53	706.50	1766.25	2120	2649
300	25.43	50.87	127.2	254.34	1017	2543.40	3052	3815
350	34.62	69.24	173.1	346.19	1385	3461.85	4154	5193
400	45	90	226.1	452	1809	4522	5426	6782
450	57	114	286.1	572	2289	5723	6867	8584
500	71	141	353.3	707	2826	7065	8478	10598
600	102	203	508.7	1017	4069	10174	12208	15260
700	138	277	692.4	1385	5539	13847	16617	20771
800	181	362	904.3	1809	7235	18086	21704	27130
900	229	458	1145	2289	9156	22891	27469	34336
1000	283	565	1413	2826	11304	28260	33912	42390
1200	407	814	2035	4069	16278	40694	48833	61042
1400	554	1108	2769	5539	22156	55390	66468	83084
1600	723	1447	3617	7235	28938	72346	86815	108518
1800	916	1831	4578	9156	36625	91562	109875	137344
2000	1130	2261	5652	11304	45216	113040	135648	169560
2200	1368	2736	6839	13678	54711	136778	164134	205168
2400	1628	3256	8139	16278	65111	162778	195333	244166
2600	1910	3821	9552	19104	76415	191038	229245	286556
2800	2216	4431	11078	22156	88623	221558	265870	332338
3000	2543	5087	12717	25434	101736	254340	305208	381510



Flow Meter Site Selection General Guidelines

Evaluating Upstream Piping Conditions

↑ BETTER	Straight Pipe
	Single Bend
↓ WORSE	Pipe Reduction or Enlargement
	Outflowing Tees
	Multiple Bends in Same Plane
	Multiple Bends Out of Plane
	Inflowing Tees
	Control Valve

Helpful Formulae

Energy Calculations

$$\text{BTU/Hr} = 500 * \text{Flow Rate (GPM)} \times \text{Delta-T (°F)}$$

$$1 \text{ Ton} = 12,000 \text{ BTU/Hr}$$

Specific Flow Calculations

Calculate Flow Rate from Frequency Output

$$\text{GPM} = \frac{\text{Measured Frequency (Hz)} \times 60}{\text{Meter Factor}^{**} \text{ (PPG)}}$$

Calculate Flow Rate from Current Output (4-20 mA)

$$\text{GPM} = \frac{\text{Measured Current (mA)} - 4}{16 \text{ mA}} \times \boxed{\text{Full Scale Flow Rate}^{**}}$$

Calculate Flow Rate from Voltage Output (0-10 VDC)

$$\text{GPM} = \frac{\text{Measured Voltage (DC)}}{10} \times \boxed{\text{Full Scale Flow Rate}^{**}}$$

* Approximation for water.

** Refer to calibration tag or certificate.

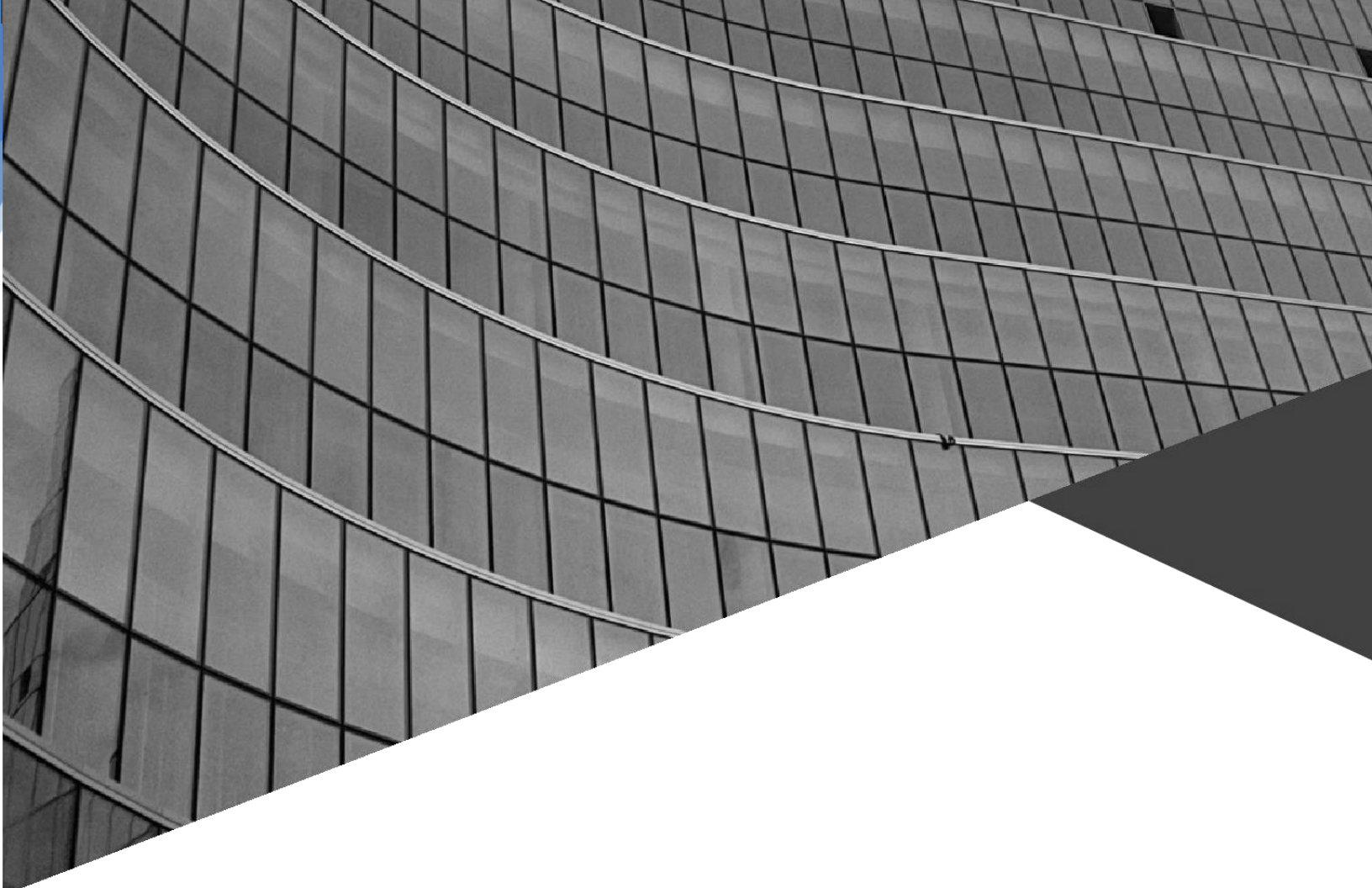

MIAL®
INSTRUMENTS PVT.LTD.
Measuring & Beyond

info@mialinstruments.com
+91 9913449547 | +91 9913449548

USA OFFICE : DOWNTOWN REPUBLIC CENTER , 325 N. ST.PAUL STREET, SUITE 3100,DALLAS 75201 ,TEXAS ,USA
FACTORY 1 : 856/6 GIDC MAKARPURA, VADODARA, GUJARAT-390010
FACTORY 2 : 0, 195, AATMIYA BROOKFIELDZ INDUSTRIAL PARK, POR, UNTIYA KAJAPUR, VADODARA, GUJARAT- 391243



www.mialinstruments.com